

# EPIC™

## VIEW 550

Model No. EPTL99609.0

Serial No. \_\_\_\_\_

Write the serial number in the space above for reference.

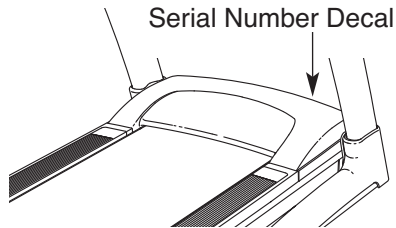

## USER'S MANUAL

### QUESTIONS?

If you have questions, or if parts are damaged or missing, **DO NOT CONTACT THE STORE**; please contact Customer Care.

**IMPORTANT:** Please register this product (see the limited warranty on the back cover of this manual) before contacting Customer Care.

CALL TOLL-FREE:

**1-866-997-6999**

Mon.–Fri. 6 a.m.–6 p.m. MT

Sat. 8 a.m.–4 p.m. MT

ON THE WEB:

[www.iconservice.com](http://www.iconservice.com)



### CAUTION

Read all precautions and instructions in this manual before using this equipment. Save this manual for future reference.



# TABLE OF CONTENTS

WARNING DECAL PLACEMENT .....	.2
IMPORTANT PRECAUTIONS .....	.3
BEFORE YOU BEGIN .....	.6
ASSEMBLY .....	.7
OPERATION AND ADJUSTMENT .....	.14
HOW TO FOLD AND MOVE THE TREADMILL .....	.27
TROUBLESHOOTING .....	.28
EXERCISE GUIDELINES .....	.32
PART LIST .....	.33
EXPLODED DRAWING .....	.35
ORDERING REPLACEMENT PARTS .....	Back Cover
LIMITED WARRANTY .....	Back Cover

## WARNING DECAL PLACEMENT

**⚠ WARNING:**

Protect yourself and others from risk of serious injury. Read the user's manual and:

-  Stand only on the side rails when starting or stopping treadmill.
- Change speed in small increments.
- Hold handrails to prevent falling, and always wear the safety clip while operating treadmill.
- Stop if you feel faint, dizzy, or short of breath.
- Fully engage storage latch before treadmill is moved or stored.
- Reduce incline to its lowest level before folding treadmill into storage position.

---

-  Never allow children on or around treadmill.
- Remove key when not in use.

---

-  Keep clothing, fingers, and hair away from moving belt.
- Never try to adjust or fix the belt while it is moving.

---

-  Always wear athletic shoes while operating treadmill.

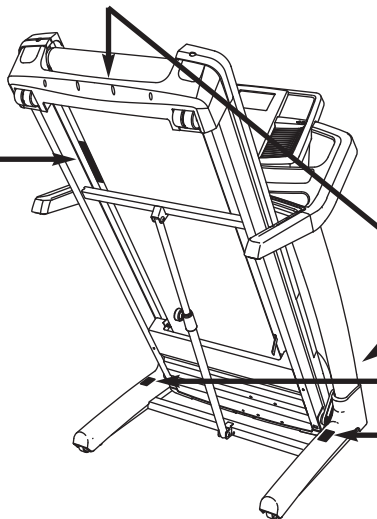

This drawing shows the locations of the warning decals. **If a decal is missing or illegible, call the telephone number on the front cover of this manual and request a free replacement decal. Apply the decal in the location shown.** Note: The decals may not be shown at actual size.

**⚠ CAUTION**

KEEP HANDS AND FEET AWAY FROM THIS AREA WHILE THE TREADMILL IS IN OPERATION.

# IMPORTANT PRECAUTIONS

**⚠ WARNING:** To reduce the risk of serious injury, read all important precautions and instructions in this manual and all warnings on your treadmill before using your treadmill. ICON assumes no responsibility for personal injury or property damage sustained by or through the use of this product.

1. Before beginning this or any exercise program, consult your physician. This is especially important for persons over age 35 or persons with pre-existing health problems.
2. It is the responsibility of the owner to ensure that all users of this treadmill are adequately informed of all warnings and precautions.
3. Use the treadmill only as described.
4. Place the treadmill on a level surface, with at least 8 ft. (2.4 m) of clearance behind it and 2 ft. (0.6 m) on each side. Do not place the treadmill on any surface that blocks air openings. To protect the floor or carpet from damage, place a mat under the treadmill.
5. Keep the treadmill indoors, away from moisture and dust. Do not put the treadmill in a garage or covered patio, or near water.
6. Do not operate the treadmill where aerosol products are used or where oxygen is being administered.
7. Keep children under age 12 and pets away from the treadmill at all times.
8. The treadmill should be used only by persons weighing 350 lbs. (159 kg) or less.
9. Never allow more than one person on the treadmill at a time.
10. Wear appropriate exercise clothes when using the treadmill. Do not wear loose clothes that could become caught in the treadmill. Athletic support clothes are recommended for both men and women. *Always wear athletic shoes. Never use the treadmill with bare feet, wearing only stockings, or in sandals.*
11. When connecting the power cord (see page 14), plug the power cord into a surge suppressor (not included) and plug the surge suppressor into a grounded circuit capable of carrying 15 or more amps. No other appliance should be on the same circuit. Do not use an extension cord.
12. Use only a single-outlet surge suppressor that meets all of the specifications described on page 14. To purchase a surge suppressor, see your local EPIC dealer or call the telephone number on the front cover of this manual and order part number 146148, or see your local electronics store.
13. Failure to use a properly functioning surge suppressor could result in damage to the control system of the treadmill. If the control system is damaged, the walking belt may slow, accelerate, or stop unexpectedly, which may result in a fall and serious injury.
14. Keep the power cord and the surge suppressor away from heated surfaces.
15. Never move the walking belt while the power is turned off. Do not operate the treadmill if the power cord or plug is damaged, or if the treadmill is not working properly. (See TROUBLESHOOTING on page 28 if the treadmill is not working properly.)
16. Read, understand, and test the emergency stop procedure before using the treadmill (see HOW TO TURN ON THE POWER on page 16).
17. Never start the treadmill while you are standing on the walking belt. Always hold the handrails while using the treadmill.

18. The treadmill is capable of high speeds. Adjust the speed in small increments to avoid sudden jumps in speed.
19. The pulse sensor is not a medical device. Various factors, including the user's movement, may affect the accuracy of heart rate readings. The pulse sensor is intended only as an exercise aid in determining heart rate trends in general.
20. Never leave the treadmill unattended while it is running. Always remove the key, unplug the power cord, and switch the reset/off circuit breaker to the "off" position when the treadmill is not in use. (See the drawing on page 6 for the location of the reset/off circuit breaker.)
21. Do not attempt to raise, lower, or move the treadmill until it is properly assembled. (See ASSEMBLY on page 7, and HOW TO FOLD AND MOVE THE TREADMILL on page 27.) You must be able to safely lift 45 lbs. (20 kg) to raise, lower, or move the treadmill.
22. Do not change the incline of the treadmill by placing objects under the treadmill.
23. When folding or moving the treadmill, make sure that the storage latch is holding the frame securely in the storage position.
24. Inspect and properly tighten all parts of the treadmill regularly.
25. Never insert or drop any object into any opening on the treadmill.
26. Over exercising may result in serious injury or death. If you feel faint or if you experience pain while exercising, stop immediately and cool down.
27. **DANGER:** Always unplug the power cord immediately after use, before cleaning the treadmill, and before performing the maintenance and adjustment procedures described in this manual. Never remove the motor hood unless instructed to do so by an authorized service representative. Servicing other than the procedures in this manual should be performed by an authorized service representative only.
28. The treadmill is intended for in-home use only. Do not use the treadmill in any commercial, rental, or institutional setting.
29. Do not store the television in temperatures below -40° F (-40° C) or above 140° F (60° C). Do not operate the television in temperatures below 23° F (-5° C) or above 90° F (35° C).
30. To protect the treadmill and television during lightning storms, unplug the power cord from the wall outlet and disconnect the cable system. This will prevent damage due to lightning and power line surges.
31. If an outside antenna or cable system is connected, be sure that the antenna or cable system is grounded to provide some protection against voltage surges and built-up static charges. Section 810 of the National Electrical Code, ANSI/NFPA No. 70-1984, provides information with respect to proper grounding of the mast and supporting structure, grounding of the lead-in wire to an antenna discharge unit, size of grounding conductors, location of antenna discharge unit, connection to grounding electrodes, and requirements for the grounding electrode.
32. An outside antenna system should not be located in the vicinity of overhead power lines or other electric light or power circuits, or where it can fall into such power lines or circuits. When installing an outside antenna system, extreme care should be taken to keep from touching such power lines or circuits, as contact with them might be fatal.
33. To reduce the risk of electric shock, do not remove the cover or the back of the television. There are no user serviceable parts inside. Refer servicing to qualified service personnel.

34. Upon completion of any service or repairs to the treadmill or the television, ask the service technician to perform safety checks to confirm that the unit is in proper operating condition.

- Use No. 10 AWG (5.3 mm<sup>2</sup>) copper, No. 8 AWG (8.4 mm<sup>2</sup>) aluminum, No. 17 AWG (1.0 mm<sup>2</sup>) copper-clad steel or bronze wire, or larger as a ground wire.
- Secure an antenna lead-in and ground wires to the house with stand-off insulators spaced from 4 to 6 feet (1.22 to 1.83 m) apart.
- Mount an antenna discharge unit as close as possible to where the lead-in enters the house.

- Use a jumper wire not smaller than No. 6 AWG (13.3 mm<sup>2</sup>) copper, or the equivalent when a separate antenna-grounding electrode is used. See NEC Section 810-21 (j).

**Note to CATV system installer:** This reminder is provided to call the CATV system installer's attention to Article 820-40 of the NEC that provides guidelines for proper grounding and, in particular, specifies that the cable ground shall be connected to the grounding system of the building, as close to the point of cable entry as practical.

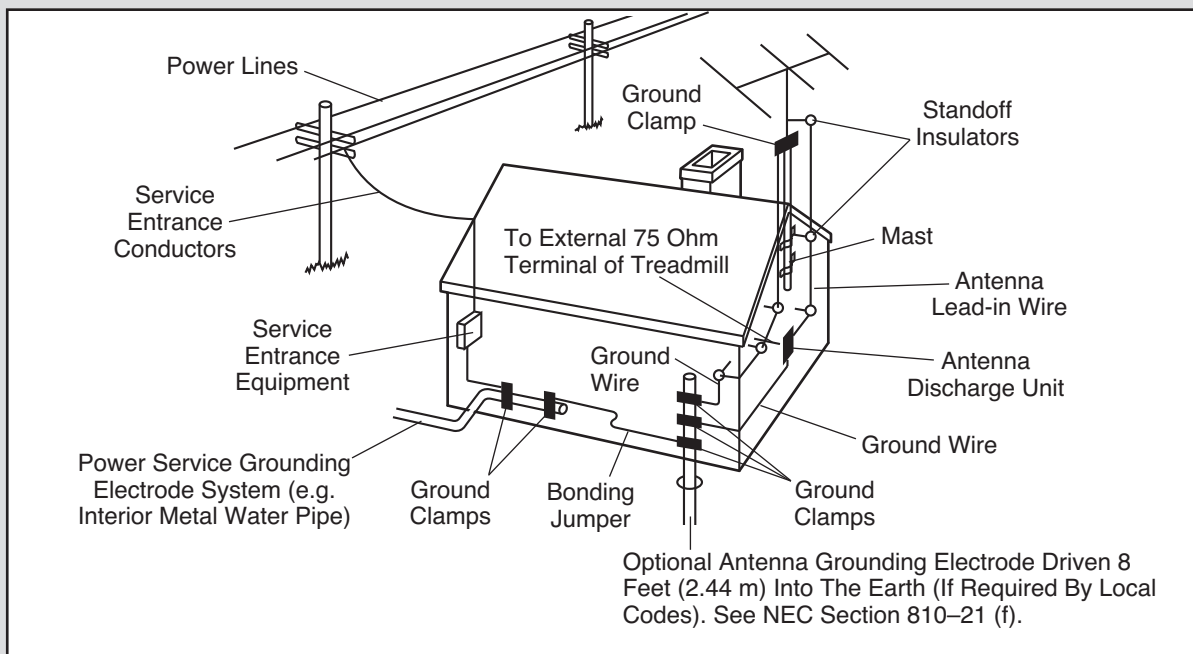

**SAVE THESE INSTRUCTIONS**

# BEFORE YOU BEGIN

Thank you for selecting the revolutionary EPIC™ VIEW 550 treadmill. The VIEW 550 treadmill offers an impressive selection of features designed to make your workouts at home more enjoyable and effective. And when you're not exercising, the unique treadmill can be folded up, requiring less than half the floor space of other treadmills.

**For your benefit, read this manual carefully before using the treadmill.** If you have questions after read-

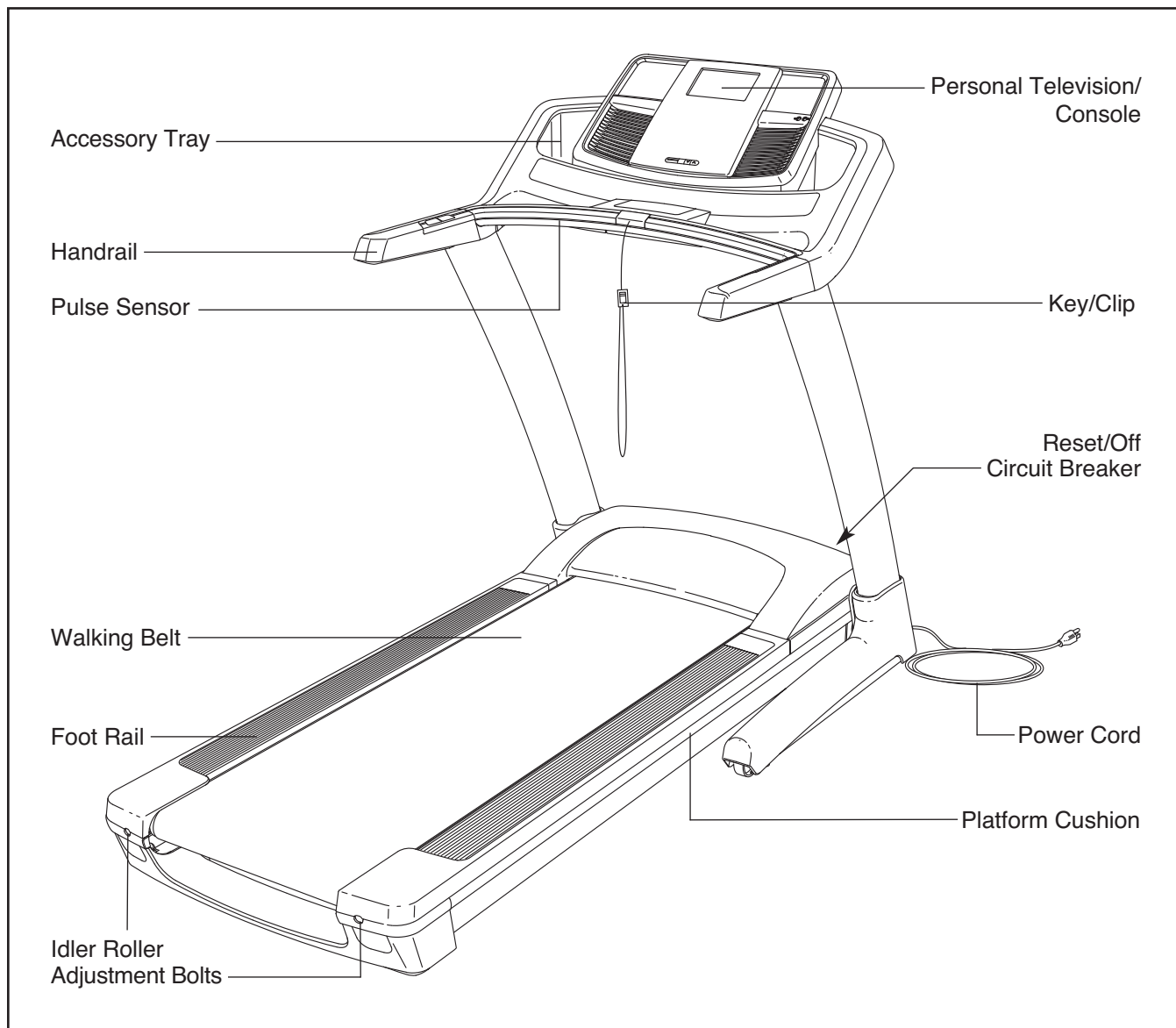

ing this manual, please see the front cover of this manual. To help us assist you, note the product model number and serial number before contacting us. The model number and the location of the serial number decal are shown on the front cover of this manual.

Before reading further, please familiarize yourself with the parts that are labeled in the drawing below.



# ASSEMBLY

To hire an authorized service technician to assemble the treadmill, call 1-800-445-2480. Assembly requires two persons. Set the treadmill in a cleared area and remove all packing materials. **Do not dispose of the packing materials until assembly is completed.** Note: The underside of the treadmill walking belt is coated with high-performance lubricant. During shipping, some lubricant may be transferred to the top of the walking belt or the shipping carton. This is normal and does not affect treadmill performance. If there is lubricant on top of the walking belt, simply wipe off the lubricant with a soft cloth and a mild, non-abrasive cleaner.

Assembly requires the included hex keys  and your own Phillips screwdriver  and adjustable wrench .

For help identifying the assembly hardware, see the drawings below. The number in parentheses below each drawing is the key number of the part, from the PART LIST near the end of this manual. The number following the parentheses is the quantity needed for assembly. **Note: If a part is not in the parts bag, check to see if it has been preassembled. To avoid damaging plastic parts, do not use power tools for assembly. Extra hardware may be included.**

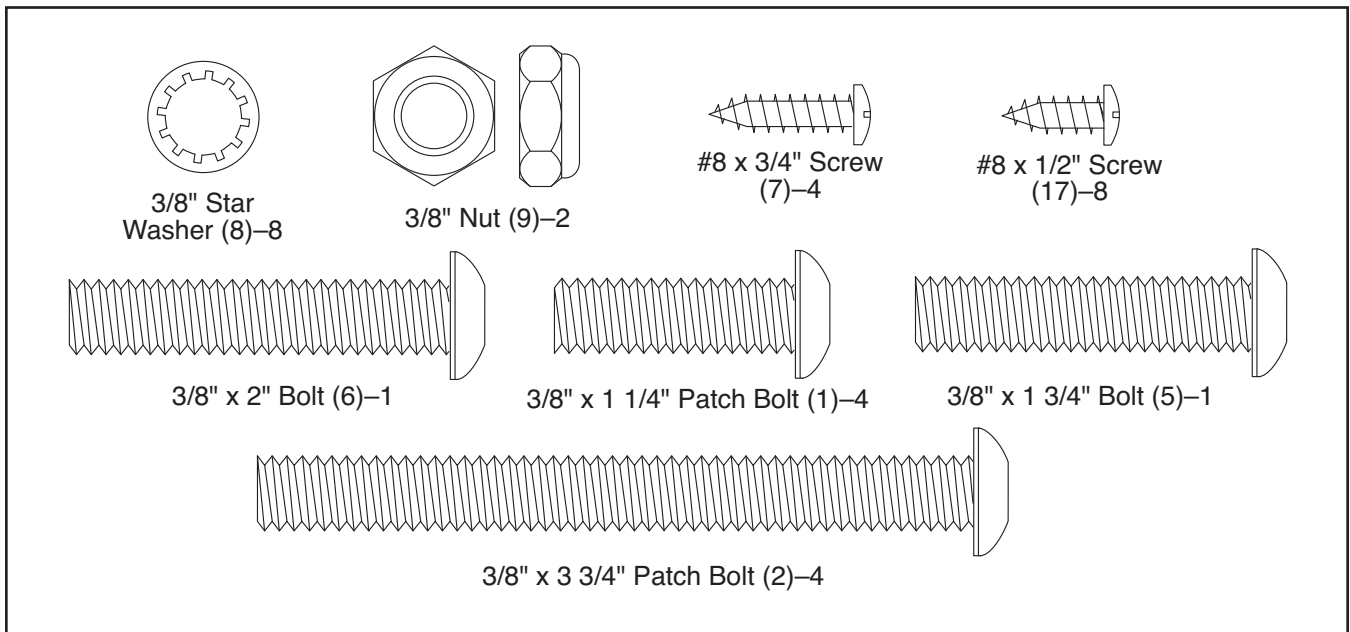

## 1. Make sure that the power cord is unplugged.

Locate the cardboard stand. With the help of a second person, raise the front of the treadmill and insert the crossbar on the Base (115) into the cutout in the cardboard stand as shown.

**Serious injury may occur if the treadmill moves forward or backward and falls off the cardboard stand. A second person must hold the treadmill until assembly step 3 is completed to prevent the treadmill from moving, tipping, or falling.**

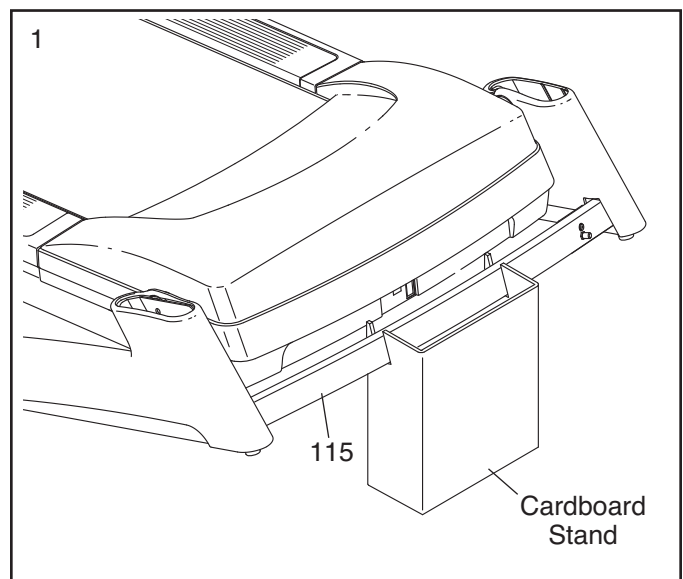

- Have a second person hold the Right Upright (88) near the Right Base Cover (117). **See the inset drawing.** Locate the wire tie in the rectangular hole in the bottom of the Right Upright. Tie the wire tie securely around the end of the Upright Wire (86). Then, pull the other end of the wire tie until the Upright Wire is routed completely through the Right Upright.

Gently pull up on the Upright Wire (86) as you set the Right Upright (88) on the Base (115) inside the Right Base Cover (117). **Be careful not to pinch the Upright Wire.**

Attach the Right Upright (88) to the Base (115) with two 3/8" x 3 3/4" Patch Bolts (2) and two 3/8" Star Washers (8); **do not fully tighten the Patch Bolts yet.** Note: It may be necessary to tip the top of the Right Upright forward slightly and rotate the bottom as you thread the Patch Bolts into the Right Upright.

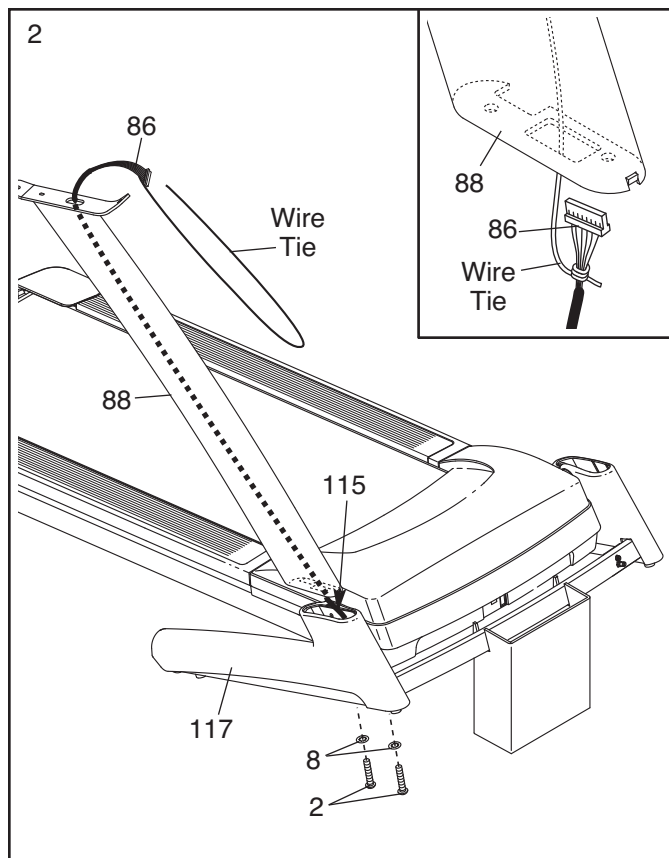

- Have a second person hold the Left Upright (85) near the Left Base Cover (118). **See the inset drawing.** Locate the wire tie in the rectangular hole in the bottom of the Left Upright. Tie the wire tie in the Left Upright securely around the end of the 65" TV Cable (81) and the 65" A/V Wire (80).

Then, pull the other end of the wire tie until the 65" A/V Wire (80) and the 65" TV Cable (81) are routed completely through the Left Upright (85). Gently pull up on the wires as you set the Left Upright on the Base (115) inside the Left Base Cover (118). **Be careful not to pinch the wires.**

Attach the Left Upright (85) to the Base (115) with two 3/8" x 3 3/4" Patch Bolts (2) and two 3/8" Star Washers (8); **do not fully tighten the Patch Bolts yet.** Note: It may be necessary to tip the top of the Left Upright forward slightly and rotate the bottom as you thread the Patch Bolts into the Left Upright.

With the help of a second person, lower the treadmill off the cardboard stand. The stand will be used again in assembly step 8.

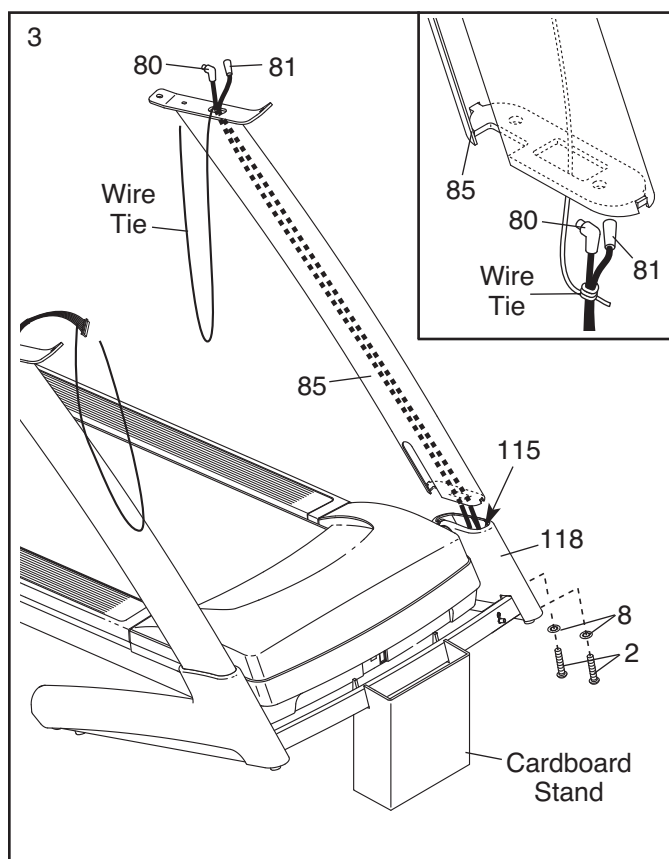



4. Set the console assembly face down on a soft surface to avoid scratching the console assembly.

Identify the Left Accessory Tray (90) and the Right Accessory Tray (100).

Attach the Left Accessory Tray (90) and the Right Accessory Tray (100) to the console assembly with eight #8 x 1/2" Screws (17).

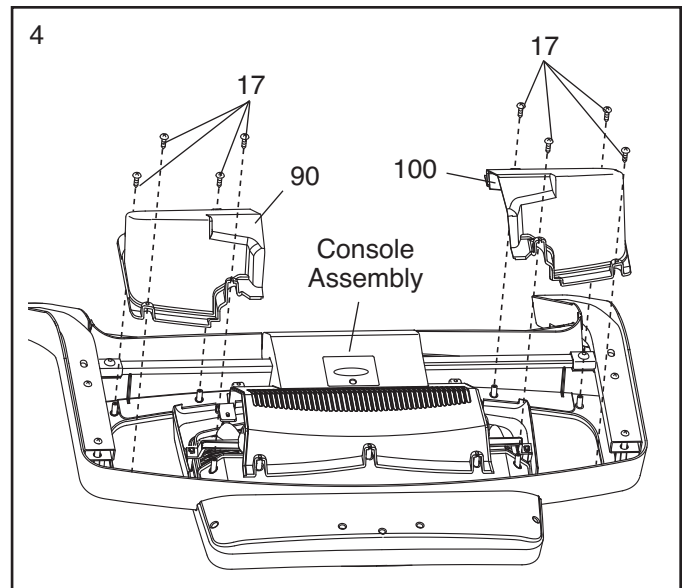

5. With the help of a second person, hold the console assembly near the Uprights (85, 88).

Connect the 65" A/V Wire (80) and the 65" TV Cable (81) to the A/V wire and the 40" TV Cable (62) extending from the console assembly.

Connect the Upright Wire (86) to the console wire extending from the console assembly. **See the inset drawing. The connectors should slide together easily and snap into place. If they do not, turn one connector and try again. IF THE CONNECTORS ARE NOT CONNECTED PROPERLY, THE CONSOLE MAY BE DAMAGED WHEN THE POWER IS TURNED ON.**

Remove the wire tie from the Upright Wire (86). Remove the wire tie from the 65" A/V Wire (80) and the 65" TV Cable (81).

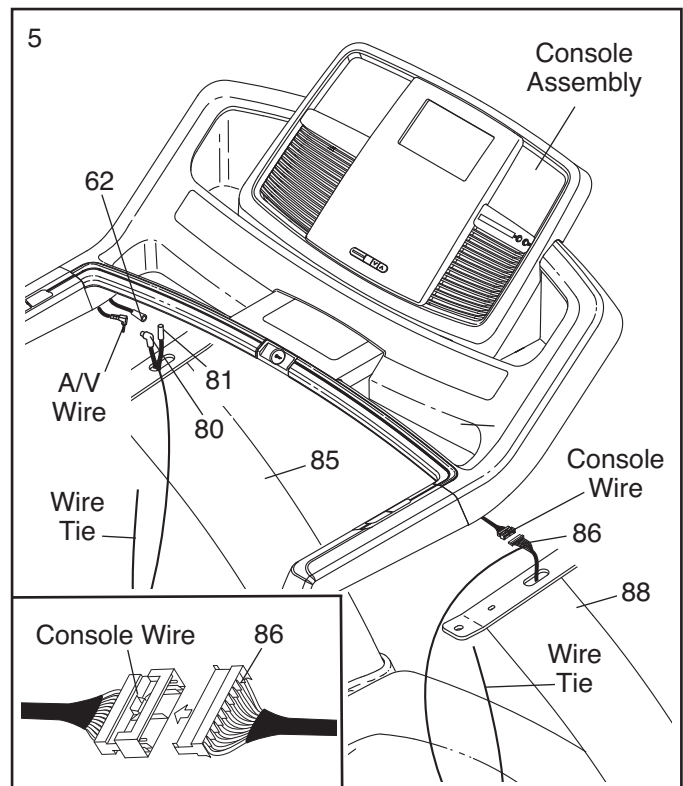

6. Insert the wires from step 5 into the Uprights (85, 88) as you set the console assembly on the Uprights. **Be careful not to pinch any wires.**

Attach the console assembly with four 3/8" x 1 1/4" Patch Bolts (1) and four 3/8" Star Washers (8). **Start all four Bolts before tightening any of them.**

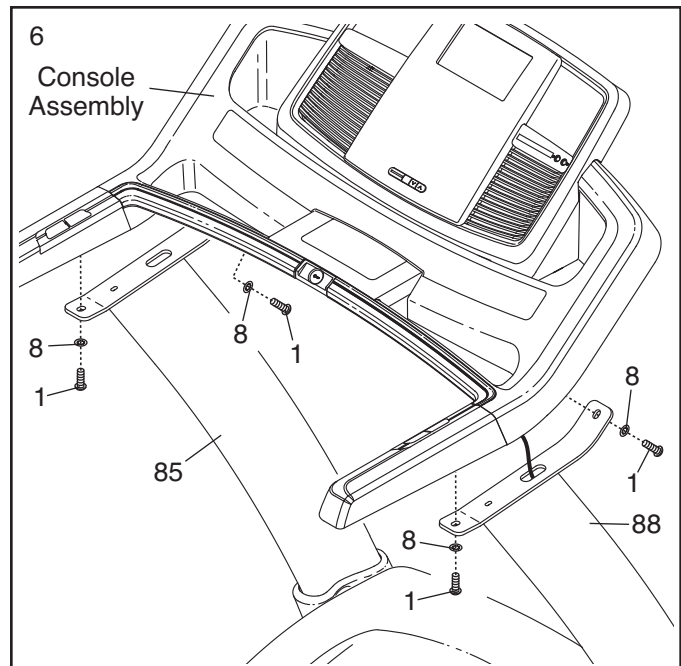

7. Attach the Right Bottom Handrail Cover (104) and the Left Bottom Handrail Cover (106) to the console assembly with four #8 x 3/4" Screws (7).

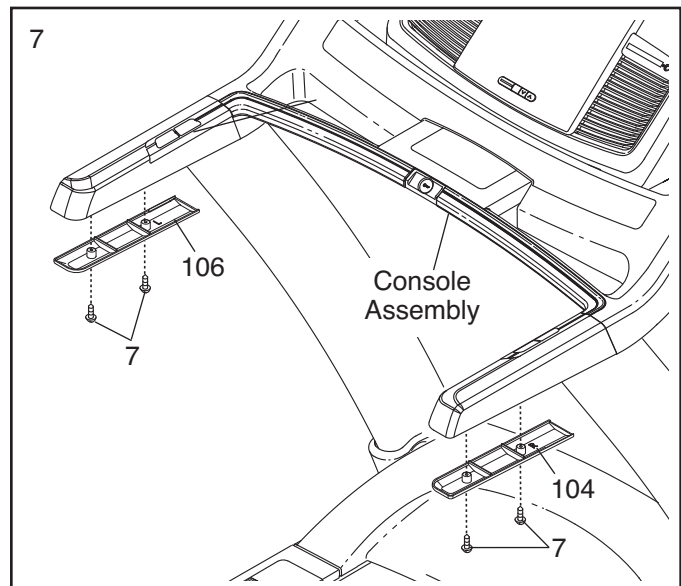

8. Locate the cardboard stand used for step 1. With the help of a second person, raise the front of the treadmill and insert the crossbar on the Base (115) into the cutout in the cardboard stand as shown. **Have the second person hold the treadmill to prevent it from moving forward or backward.**

Firmly tighten the four 3/8" x 3 3/4" Patch Bolts (2).

With the help of a second person, lower the treadmill off the cardboard stand.

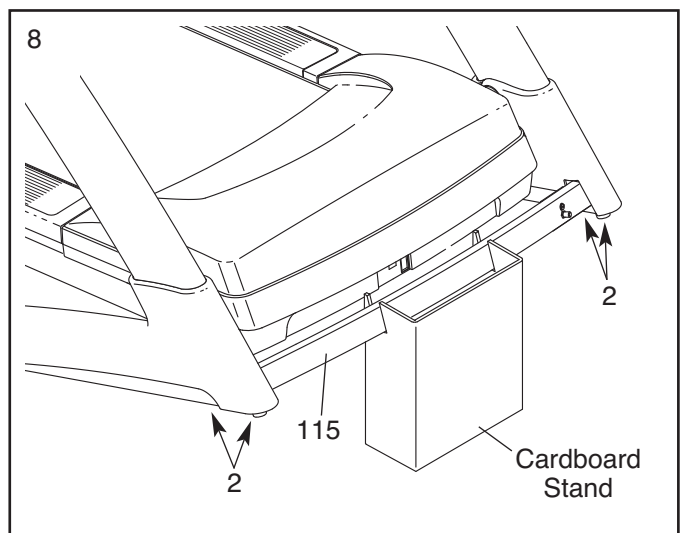

9. Orient the Storage Latch (78) so that the large barrel and the Latch Knob (77) are in the positions shown.

Remove the tie from the upper end of the Storage Latch (78). Attach the upper end of the Storage Latch to the bracket on the Frame (61) with a 3/8" x 1 3/4" Bolt (5) and a 3/8" Nut (9).

Remove the tie from the lower end of the Storage Latch (78). Keep the holes in the Latch Cap (79) aligned with the holes in the Storage Latch. **Make sure to keep the Latch Cap inside the Storage Latch.** Attach the Storage Latch to the bracket on the Base (115) with a 3/8" x 2" Bolt (6) and a 3/8" Nut (9). Note: It may be necessary to move the Frame back and forth to align the Storage Latch with the bracket.

Lower the Frame (61) (see HOW TO LOWER THE TREADMILL FOR USE on page 27).

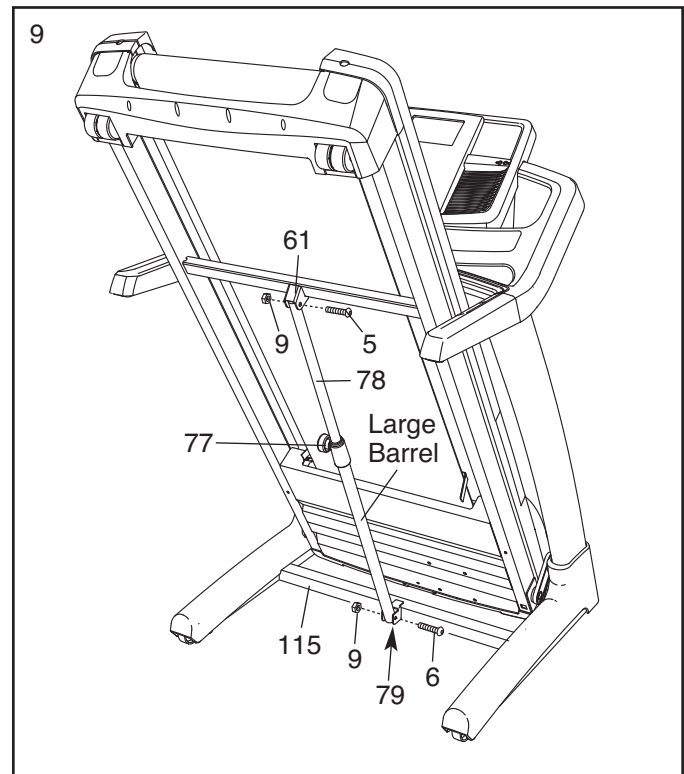

10. Note the location of the 75 ohm terminal and the audio/video input jack on the treadmill. For the television to operate, an antenna or a CATV cable must be connected to the 75 ohm terminal or the 96" A/V Wire (101) must be connected to the audio/video input jack (see page 13).

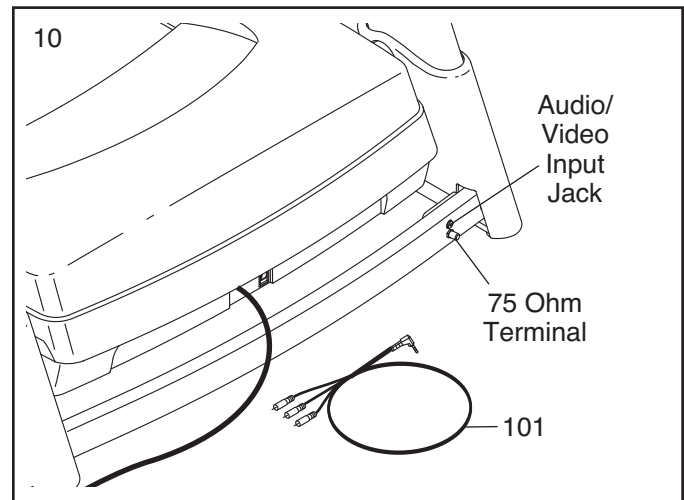

11. **Make sure that all parts are properly tightened before you use the treadmill.** Keep the included hex keys in a secure place; one of the hex keys is used to adjust the walking belt (see pages 29 and 30). **To protect the floor or carpet from damage, place a mat under the treadmill.**

If you purchase the optional chest pulse sensor (see page 26), follow the steps below to install the receiver included with the chest pulse sensor.

1. **Make sure that the power cord is unplugged.** Remove the indicated #8 x 1/2" Screw (17) from the Pulse Receiver Cover (95) on the back of the console assembly.

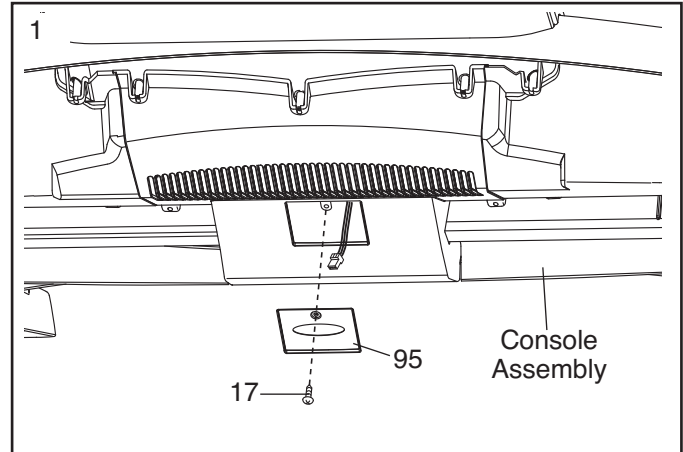

2. **Next, hold the receiver so that the antenna is oriented as shown.** Peel the paper backing off the pad on the bottom of the receiver. Press the receiver onto the Pulse Receiver Cover (95) in the location shown.

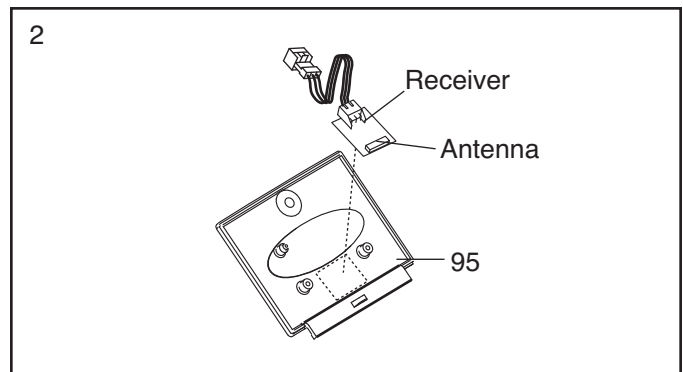

3. Connect the wire on the receiver to the wire extending from the console assembly. **Make sure that no wires are pinched.** Reattach the Pulse Receiver Cover (95) to the console assembly with the #8 x 1/2" Screw (17). Discard the other wires included with the receiver.

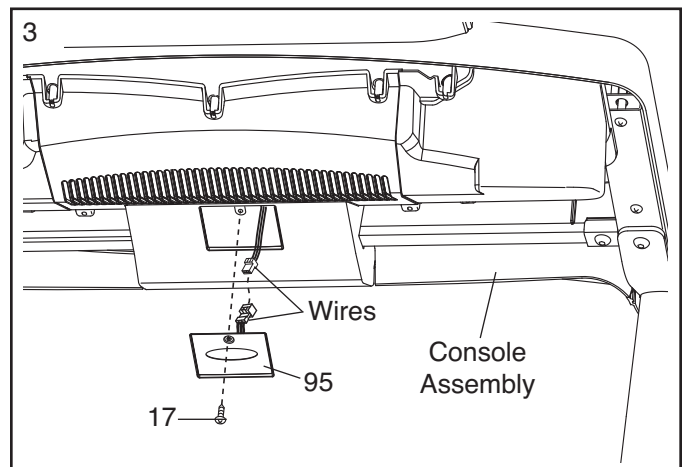

**Before operating the television, you must connect an antenna or a 75 ohm CATV cable to the 75 ohm terminal or the 96" A/V Wire to the audio/video input jack. No CATV cable, antenna, or adapter is included.**

**HOW TO CONNECT AN ANTENNA**

Place an indoor antenna or an outdoor combination VHF/UHF antenna in the desired location. Outdoor antennas are subject to weathering that can reduce signal quality. Inspect your outdoor antenna and the lead-in wiring before connecting the antenna.

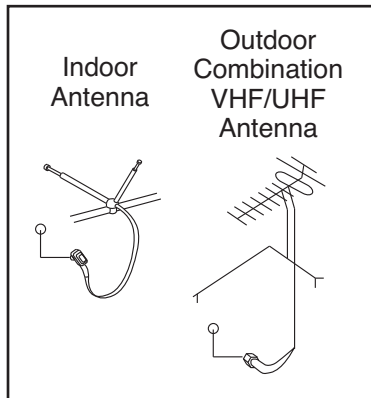

Note: Due to an FCC requirement, analog signals will no longer be broadcast over the air after June 12, 2009. If you wish to view television signals through an antenna after that date, you must have an antenna capable of receiving digital signals or a digital converter box. Cable television will not be affected.

**HOW TO CONNECT AN EXTERNAL SOURCE USING A CATV CABLE**

Use a CATV cable to connect to an external source such as a cable box, satellite TV box, VCR, or analog cable.

1. Connect one end of a 75 ohm CATV cable to the 75 ohm output jack on your external source.
2. Plug in the power cord of your external source. See your external source user's manual for proper grounding instructions.
3. Connect the 75 ohm CATV cable to the 75 ohm terminal on the treadmill frame near the power cord. See the drawing at the left.

**75 Ohm CATV Cable**

1. Connect the 75 ohm CATV cable from the antenna to the 75 ohm terminal on the treadmill frame near the power cord.

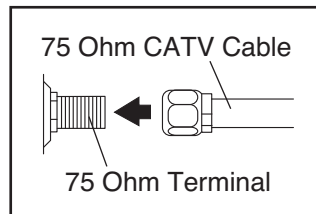

**HOW TO CONNECT AN EXTERNAL SOURCE USING THE 96" A/V WIRE**

Use the 96" A/V Wire to connect to an external source such as a VCR or DVD player.

1. Connect the three-pronged end of the 96" A/V Wire to your external source.

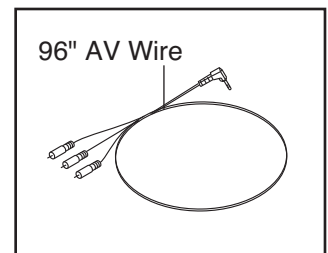

**300 Ohm Flat Wire**

1. Connect the 300 ohm flat wire from the antenna to a 300 ohm to 75 ohm adapter.

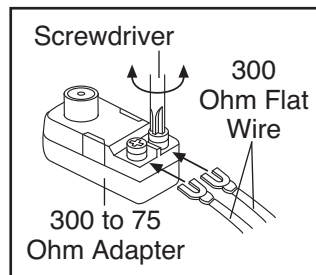

2. Connect the 300 ohm to 75 ohm adapter to the 75 ohm terminal on the treadmill frame near the power cord.

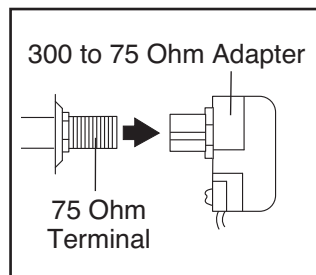

2. Plug in the power cord of your external source. See your external source user's manual for proper grounding instructions.
3. Connect the 96" A/V Wire to the audio/video input jack on the treadmill frame near the power cord.

# OPERATION AND ADJUSTMENT

## THE PRE-LUBRICATED WALKING BELT

Your treadmill features a walking belt coated with high-performance lubricant. **IMPORTANT: Never apply silicone spray or other substances to the walking belt or the walking platform. Such substances will deteriorate the walking belt and cause excessive wear.**

## HOW TO PLUG IN THE POWER CORD

**⚠ DANGER:** Improper connection of the equipment-grounding conductor can result in an increased risk of electric shock. Check with a qualified electrician or serviceman if you are in doubt as to whether the product is properly grounded. Do not modify the plug provided with the product—if it will not fit the outlet, have a proper outlet installed by a qualified electrician.

Your treadmill, like any other type of sophisticated electronic equipment, can be seriously damaged by sudden voltage changes in your home's power. Voltage surges, spikes, and noise interference can result from weather conditions or from other appliances being turned on or off. **To decrease the possibility of your treadmill being damaged, always use a surge suppressor with your treadmill (see drawing 1 at the right).** To purchase a surge suppressor, see your local EPIC dealer or call the telephone number on the front cover of this manual and order part number 146148, or see your local electronics store.

Use only a single-outlet surge suppressor that is UL 1449 listed as a transient voltage surge suppressor (TVSS). The surge suppressor must have a UL suppressed voltage rating of 400 volts or less and a minimum surge dissipation of 450 joules. The surge suppressor must be electrically rated for 120 volts AC and 15 amps. There must be a monitoring light on the surge suppressor to indicate whether it is functioning properly. Failure to use a properly functioning surge suppressor could result in damage to the control system of the treadmill. If the control system is damaged, the walking belt may slow, accelerate, or stop unexpectedly, which may result in a fall and serious injury.

**This product must be grounded.** If it should malfunction or break down, grounding provides a path of least resistance for electric current to reduce the risk of elec-

tric shock. This product is equipped with a cord having an equipment-grounding conductor and a grounding plug. **Plug the power cord into a surge suppressor, and plug the surge suppressor into an appropriate outlet that is properly installed and grounded in accordance with all local codes and ordinances. IMPORTANT: The treadmill is not compatible with GFCI-equipped outlets.**

This product is for use on a nominal 120-volt circuit, and has a grounding plug that looks like the plug illustrated in drawing 1 below. A temporary adapter that looks like the adapter illustrated in drawing 2 may be used to connect the surge suppressor to a 2-pole receptacle as shown in drawing 2 if a properly grounded outlet is not available.

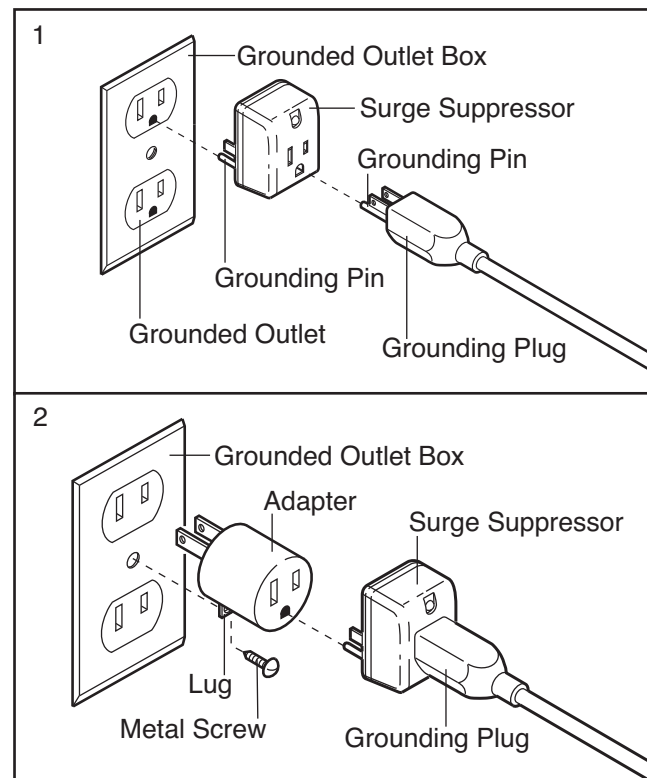

The temporary adapter should be used only until a properly grounded outlet (drawing 1) can be installed by a qualified electrician.

The green-colored rigid ear, lug, or the like extending from the adapter must be connected to a permanent ground such as a properly grounded outlet box cover. Whenever the adapter is used it must be held in place by a metal screw. **Some 2-pole receptacle outlet box covers are not grounded. Contact a qualified electrician to determine if the outlet box cover is grounded before using an adapter.**

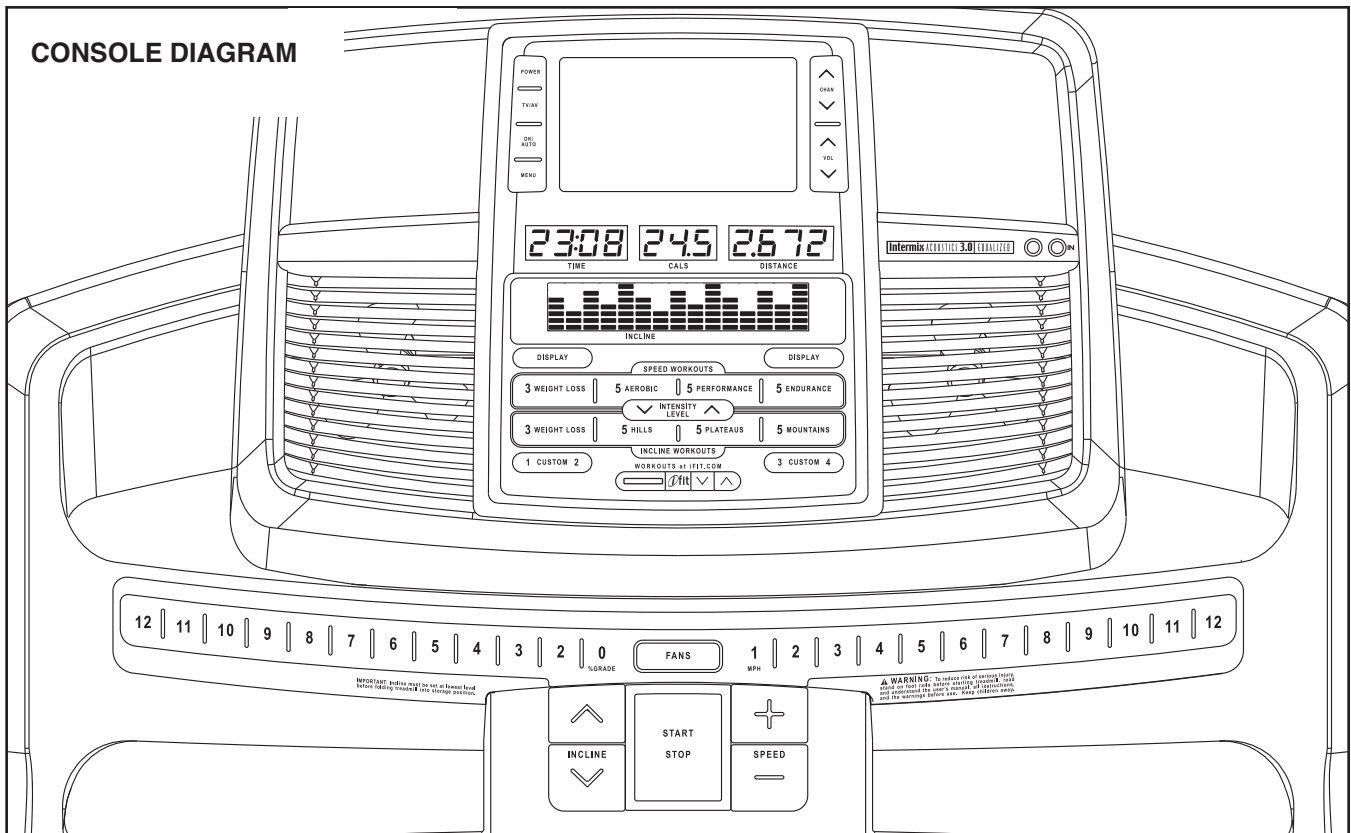

## FEATURES OF THE CONSOLE

The treadmill console offers an impressive selection of features designed to make your workouts more effective and enjoyable. When the manual mode of the console is selected, the speed and incline of the treadmill can be changed with the touch of a button. As you exercise, the console will display continuous exercise feedback. You can even measure your heart rate using the handgrip pulse sensor or the optional chest pulse sensor. See page 26 for information about the optional chest pulse sensor.

In addition, the console features thirty-six preset workouts. Each workout automatically controls the speed and incline of the treadmill as it guides you through an effective exercise session. You can even create your own custom workouts and save them for future use.

The console also features the new iFit Interactive Workout system. The iFit system enables the console to accept iFit Interactive Workout Cards containing workouts designed to help you achieve specific fitness goals. For example, lose unwanted pounds with the 8-week Weight Loss workout, or train for a long-distance

run with the Marathon workout. iFit workouts automatically control the treadmill while the voice of a personal trainer coaches you through every step of your workout. iFit cards are available separately. **To purchase iFit cards at any time, go to [www.iFit.com](http://www.iFit.com) or call the telephone number on the front cover of this manual. iFit cards are also available at select stores.**

Whether you select the manual mode or a workout, you can enjoy the shows of your choice on the personal television while you get in shape. You can also listen to your favorite workout music or audio books with the console's premium stereo sound system.

**To turn on the power**, see page 16. **To use the manual mode**, see page 16. **To use a preset workout**, see page 18. **To create and use a custom workout**, see pages 19 and 20. **To use an iFit workout**, see page 21. **To operate the personal television**, see page 22. **To use the remote control**, see page 23. **To replace the batteries in the remote control**, see page 23. **To adjust television settings**, see page 24. **To use the information mode**, see page 26. **To use the stereo sound system**, see page 26.

## HOW TO TURN ON THE POWER

**IMPORTANT:** If the treadmill has been exposed to cold temperatures, allow it to warm to room temperature before turning on the power. If you do not do this, you may damage the console displays or other electrical components.

Plug in the power cord (see page 14). Next, locate the reset/off circuit breaker on the treadmill frame near the power cord. Make sure that the circuit breaker is in the “reset” position.

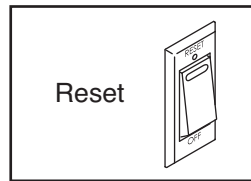

**IMPORTANT:** The console features a display demo mode, designed to be used if the treadmill is displayed in a store. If the displays light as soon as you plug in the power cord and switch the reset/off circuit breaker to the reset position, the demo mode is turned on. To turn off the demo mode, hold down the Start/Stop button for a few seconds. If the displays remain lit, see THE INFORMATION MODE on page 26 to turn off the demo mode.

Next, stand on the foot rails of the treadmill. Locate the clip attached to the key (see the drawing at the right), and slide the clip securely onto the waistband of your clothes. Then, insert the key into the console. After a moment, the displays will light.

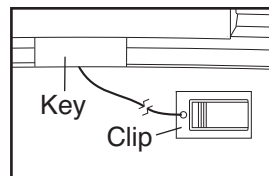

**IMPORTANT:** In an emergency situation, the key can be pulled from the console, causing the walking belt to slow to a stop. Test the clip by carefully taking a few steps backward; if the key is not pulled from the console, adjust the position of the clip.

**IMPORTANT:** If there is a sheet of clear plastic on the face of the console, remove the plastic. To prevent damage to the walking platform, wear clean athletic shoes while using the treadmill. The first time the treadmill is used, observe the alignment of the walking belt, and center the walking belt if necessary (see page 30).

Note: The console can display speed and distance in either miles or kilometers. To find out which unit of measurement is selected or to change the unit of measurement, see THE INFORMATION MODE on page 26. For simplicity, all instructions in this section refer to miles.

## HOW TO USE THE MANUAL MODE

### 1. Insert the key into the console.

See HOW TO TURN ON THE POWER at the left.

### 2. Select the manual mode.

Each time the key is inserted, the manual mode will be selected. If you have selected a workout, press any of the workout buttons repeatedly until a track appears in the matrix.

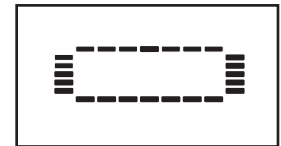

### 3. Start the walking belt and adjust the speed.

To start the walking belt, press the Start/Stop button, one of the Speed increase buttons, or one of the speed buttons numbered 1 to 12.

If you press the Start button or one of the Speed increase buttons, the walking belt will begin to move at 1 mph. As you exercise, change the speed of the walking belt as desired by pressing the Speed increase and decrease buttons on the console or in the right handrail. Each time you press a button, the speed setting will change by 0.1 mph; if you hold down the button, the speed setting will change in increments of 0.5 mph. If you press one of the numbered speed buttons, the walking belt will gradually change speed until it reaches the selected speed setting.

To stop the walking belt, press the Start/Stop button. To restart the walking belt, press the Start/Stop button, one of the Speed increase buttons, or one of the numbered speed buttons.

### 4. Change the incline of the treadmill as desired.

To change the incline of the treadmill, press one of the Incline increase or decrease buttons or one of the incline buttons numbered 0 to 12.

Each time you press one of the Incline increase or decrease buttons on the console or in the left handrail, the incline will change by 0.5%. If you press one of the numbered incline buttons, the incline will gradually change until it reaches the selected incline setting. Note: After you press the buttons, it may take a moment for the treadmill to reach the selected incline setting.



## 5. Follow your progress with the displays.

**The matrix**—When you select the manual mode, the matrix will display a track that represents 1/4 mile (400 meters). As you exercise, the indicators around the track will appear in succession until the entire track appears. The track will then disappear and the indicators will again begin to appear in succession.



**The Time/Incline display**—The Time/Incline display can show the elapsed time. The display can also show the incline of the treadmill

for several seconds each time the incline changes. Press the Display button below the Time/Incline display until the display shows the information that you are most interested in viewing. Note: When a workout is selected, the display will show the time remaining in the workout instead of the elapsed time.



**The Calorie/Pulse display**—The Calorie/Pulse display can show the approximate number of calories you have burned. The display will also show your heart rate when you use the handgrip pulse sensor or the optional chest pulse sensor.



**The Distance/Speed display**—The Distance/Speed display will show the distance that you have walked or run and the speed of the walking belt for a few seconds each. Press the Display button below the Distance/Speed display until the display shows the information that you are most interested in viewing.



To reset the console, press the Start/Stop button, remove the key, and then reinsert the key.

## 6. Measure your heart rate if desired.

**Note:** If you use the handgrip pulse sensor and the optional chest pulse sensor at the same

time, the console will not display your heart rate accurately. See page 26 for information about the optional chest pulse sensor.

Before using the handgrip pulse sensor, remove the sheets of clear plastic from the metal contacts. In addition, make sure that your hands are clean.

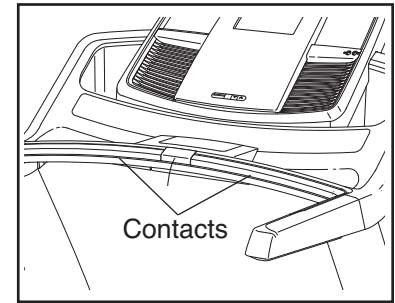

To measure your heart rate, **stand on the foot rails** and hold the metal contacts on the handrail for approximately ten seconds—**avoid moving your hands**. When your pulse is detected, several dashes will appear in the display and then your heart rate will be shown. **For the most accurate heart rate reading, continue to hold the contacts for about 15 seconds.**

## 7. Turn on the fans if desired.

The fans feature high and low speed settings. Press the Fans button repeatedly to select a fan speed or to turn off the fans. Note: If the fans are on when the walking belt is stopped, the fans will turn off automatically after a few minutes.

## 8. When you are finished exercising, remove the key from the console.

Step onto the foot rails, press the Start/Stop button, and **adjust the incline of the treadmill to the lowest setting. The incline must be at the lowest setting when you fold the treadmill to the storage position, or you may damage the treadmill.** Next, remove the key from the console and put it in a secure place.

When you are finished using the treadmill, switch the reset/off circuit breaker to the "off" position and unplug the power cord. **IMPORTANT: If you do not do this, the treadmill's electrical components may wear prematurely.**

## HOW TO USE A PRESET WORKOUT

### 1. Insert the key into the console.

See HOW TO TURN ON THE POWER on page 16.

### 2. Select a preset workout.

To select a preset workout, press one of the Weight Loss buttons, the Aerobic button, the Performance button, the Endurance button, the Hills button, the Plateaus button, or the Mountains button.

When a preset workout is selected, the displays will show the workout number and the maximum speed setting of the workout. The duration and the maximum incline setting of the workout will appear in the displays for a few seconds each. In addition, a profile of the speed or incline settings of the workout will scroll across the matrix.



To change the intensity level of the entire program, press the Intensity Level increase and decrease buttons. The intensity level will appear in the Calorie/Pulse display.

### 3. Start the walking belt.

Press the Start/Stop button or the Speed increase button to start the workout. A moment after you press the Start/Stop button, the treadmill will automatically adjust to the first speed and incline settings of the workout. Hold the handrails and begin walking.

Each workout is divided into one-minute segments. One speed setting and one incline setting are programmed for each segment. Note: The same speed and/or incline setting may be programmed for consecutive segments.

During the workout, the profile will show your progress. The flashing segment of the profile represents the current segment of the workout. If you are using a speed workout, the height of the flashing segment indicates the speed setting for the cur-

rent segment. If you are using an incline workout, the height of the flashing segment indicates the incline setting for the current segment. At the end of each segment, a series of tones will sound and the next segment of the profile will begin to flash. If a new speed and/or incline setting is programmed for the next segment, the new speed and/or incline setting will appear in the displays for a few seconds. The treadmill will automatically adjust to the new speed and/or incline setting.

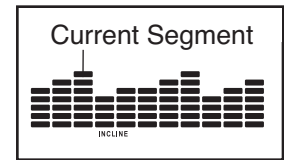

The workout will continue in this way until the last segment of the workout ends. The walking belt will then slow to a stop.

If the speed or incline setting is too high or too low at any time during the workout, you can manually override the setting by pressing the speed or incline buttons; **however, when the next segment of the workout begins, the treadmill will automatically adjust to the speed and incline settings for the next segment.**

To stop the workout at any time, press the Start/Stop button. To restart the workout, press the Start/Stop button or the Speed increase button. The walking belt will begin to move at 1 mph. When the next segment of the workout begins, the treadmill will automatically adjust to the speed and incline settings for the next segment.

### 4. Follow your progress with the displays.

See step 5 on page 17.

### 5. Measure your heart rate if desired.

See step 6 on page 17.

### 6. Turn on the fans if desired.

See step 7 on page 17.

### 7. When you are finished exercising, remove the key from the console.

See step 8 on page 17.

## HOW TO CREATE A CUSTOM WORKOUT

### 1. Insert the key into the console.

See HOW TO TURN ON THE POWER on page 16.

### 2. Select a custom workout.

To select a custom workout, press the one of the Custom buttons repeatedly. When a custom workout is selected, the displays will show the workout number and the maximum speed setting of the workout. The duration and the maximum incline setting of the workout will appear in the displays for a few seconds each. In addition, a profile of the speed settings of the workout will scroll across the matrix.

**Note: If the profile does not look like the profile at the right, see HOW TO USE A CUSTOM WORKOUT on page 20.**

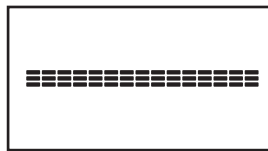

### 3. Start the walking belt and program the desired speed and incline settings.

Press the Start/Stop button or the Speed increase button to start the workout. A moment after you press the Start/Stop button, the walking belt will begin to move. Hold the handrails and begin walking.

Each custom workout is divided into several one-minute segments. One speed setting and one incline setting can be programmed for each seg-

ment. To program speed and incline settings for the first segment, simply adjust the speed and incline of the treadmill as desired by pressing the speed and incline buttons.

When the first segment of the workout ends, a series of tones will sound and the current speed and incline settings will be saved in memory. Program a speed setting and an incline setting for the second segment in the same way.

Continue programming speed and incline settings for as many segments as desired; custom workouts can have up to forty segments. When you are finished with your workout, press the Start/Stop button and remove the key from the console. The speed and incline settings that you have programmed and the workout time will then be saved in memory.

### 4. Follow your progress with the displays.

See step 5 on page 17.

### 5. Measure your heart rate if desired.

See step 6 on page 17.

### 6. Turn on the fans if desired.

See step 7 on page 17.

### 7. When you are finished exercising, remove the key from the console.

See step 8 on page 17.

## HOW TO USE A CUSTOM WORKOUT

### 1. Insert the key into the console.

See HOW TO TURN ON THE POWER on page 16.

### 2. Select a custom workout.

To select a custom workout, press the one of the Custom buttons repeatedly. When a custom workout is selected, the displays will show the workout number and the maximum speed setting of the workout. The duration and the maximum incline setting of the workout will appear in the displays for a few seconds each. In addition, a profile of the speed settings of the workout will scroll across the matrix.

**Note: If the profile looks like the profile at the right, see HOW TO CREATE A CUSTOM WORKOUT on page 19.**

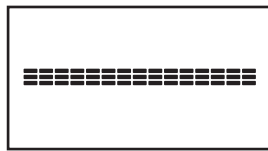

### 3. Start the walking belt.

Press the Start/Stop button or the Speed increase button to start the workout. A moment after you press the Start/Stop button, the treadmill will automatically adjust to the first speed and incline settings that you programmed previously. Hold the handrails and begin walking.

Each custom workout is divided into several one-minute segments. One speed setting and one incline setting are programmed for each segment. Note: The same speed and/or incline setting may be programmed for consecutive segments.

The custom workout will function in the same way as a preset workout (see step 3 on page 18). Note: The intensity level buttons will not function during a custom workout.

If desired, you can redesign the workout while using it. **To change the speed setting or the incline setting for the current segment**, simply press the speed or incline buttons. When the current segment ends, the new setting will be saved in memory. **To increase the length of the workout**, first wait until the workout is completed. Then, press the Start/Stop button and program speed and incline settings for as many additional segments as desired. When you have added as many segments as desired, press the Start/Stop button and remove the key from the console. **To decrease the length of the workout**, press the Start/Stop button and remove the key from the console at any time before the workout is completed.

To stop the workout temporarily, press the Start/Stop button. To restart the workout, press the Start/Stop button. The walking belt will begin to move at 1 mph. When the next segment of the workout begins, the treadmill will automatically adjust to the speed and incline settings programmed for the next segment.

### 4. Follow your progress with the displays.

See step 5 on page 17.

### 5. Measure your heart rate if desired.

See step 6 on page 17.

### 6. Turn on the fans if desired.

See step 7 on page 17.

### 7. When you are finished exercising, remove the key from the console.

See step 8 on page 17.

## HOW TO USE AN IFIT WORKOUT

To purchase iFit cards at any time, go to [www.iFit.com](http://www.iFit.com) or call the telephone number on the front cover of this manual. iFit cards are also available at select stores.

### 1. Insert the key into the console.

See HOW TO TURN ON THE POWER on page 16.

### 2. Insert an iFit card and select a workout.

To use an iFit workout, insert an iFit card into the iFit slot; make sure that the iFit card is oriented so the metal contacts are face-down and are inserted into the iFit slot. When the iFit card is properly inserted, the iFit logo will light.

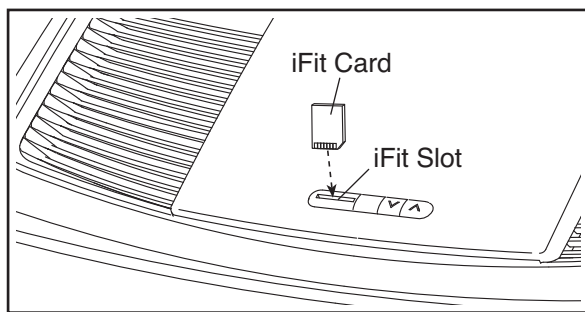

Next, select an iFit workout by pressing the iFit increase and decrease buttons next to the iFit slot. When an iFit workout is selected, the displays will show the maximum speed setting of the workout. The duration of the workout and the workout number will appear in the display for a few seconds each. In addition, a profile of the speed settings of the workout will scroll across the matrix.

Each iFit workout is divided into several one-minute segments. One speed setting and one incline setting are programmed for each segment. Note: The same speed and/or incline setting may be programmed for consecutive segments.

### 3. Start the walking belt.

Press the Start/Stop button or the Speed increase button to start the workout. A moment after you press the button, the treadmill will automatically adjust to the first speed and incline settings of the workout. Hold the handrails and begin walking.

During the workout, a personal trainer will guide you through the workout.

If the speed or incline setting for the current segment is too high or too low, you can manually override the setting by pressing the speed or incline buttons; **however, when the next segment begins, the treadmill will automatically adjust to the speed and incline settings for the next segment.**

To stop the workout at any time, press the Start/Stop button. To restart the workout, press the Start/Stop button or the Speed increase button. The walking belt will begin to move. When the next segment of the workout begins, the treadmill will automatically adjust to the speed and incline settings for the next segment.

### 4. Follow your progress with the displays.

See step 5 on page 17.

### 5. Turn on the fans if desired.

See step 7 on page 17.

### 6. When you are finished exercising, remove the key from the console.

See step 8 on page 17.

**CAUTION: Always remove iFit cards from the iFit slot when you are not using them.**

## HOW TO OPERATE THE PERSONAL TELEVISION

**IMPORTANT:** Before operating the television, you must connect the 96" A/V Wire or a CATV cable to the treadmill (see page 13).

### 1. Turn on the television.

If there is a sheet of clear plastic on the television screen, remove the plastic. Insert the key into the console. See HOW TO TURN ON THE POWER on page 16. Press the Power button to turn on the television. Note: If you operate the television without inserting the key into the console, the buttons on the console will not function.

### 2. Scan for television channels.

Before operating your television, you must scan for channels. See page 25 for information on scanning for channels. Note: To use a VCR or DVD player, you must connect a VCR or DVD player and then scan for channels.

Your television can receive analog and digital signals. For the television to operate properly, good reception is necessary. Make sure the television settings are set correctly (see HOW TO ADJUST THE TELEVISION SETTINGS on page 24). If you are using an antenna, make sure that it is properly connected and adjusted for optimal reception (see HOW TO CONNECT AN ANTENNA on page 13).

### 3. Select a television source.

Select a television source by pressing the TV/AV button repeatedly. If you have connected an antenna or a 75 ohm CATV cable to the 75 ohm terminal on the treadmill, select the TV source. If you

have plugged the 96" A/V Wire into the audio/video input jack, select the AV source.

To use a VCR or DVD player, make sure the VCR or DVD player is connected correctly (see page 13). Select the AV source and press play on your VCR or DVD player.

### 4. Select the desired channel.

When you turn on the television, the screen will show the last channel that was selected. To select a different channel, press the numbered channel buttons on the remote or the Channel increase and decrease buttons. The selected channel number will appear on the screen for a few seconds. Note: Before channels can be selected, they must be saved in the television's memory (see page 25).

### 5. Adjust the volume.

Press the Volume increase or decrease buttons on the console to change the volume. Note: For best results, change the volume by pressing the Volume buttons on the console only. Make sure the audio wire is not plugged into the audio jack on the console.

To use earphones or headphones (not included), plug them into the headphone jack near the audio jack.

### 6. Turn off the television.

When you are finished using the television, press the TV power button to turn off the television.

## HOW TO USE THE REMOTE CONTROL

The first time you use the remote control, insert batteries (see HOW TO REPLACE THE BATTERIES IN THE REMOTE CONTROL at the right).

Next, stand on the treadmill and hold the remote control near the television. Point the remote control directly at the television.

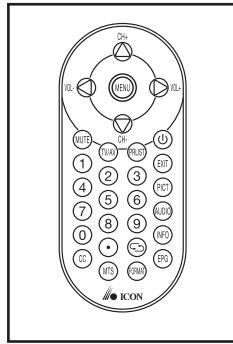

Press the Power button (⏻). After a few moments, the television will turn on or turn off.

Press the Volume (VOL) increase or decrease button to navigate left or right in a menu. For best results, change the volume by pressing the Volume buttons on the console only.

Press the Mute button to turn on or turn off the sound.

Press the numbered channel buttons or the Channel (CH) increase or decrease button to select a channel. The Channel increase and decrease buttons on the remote also function as the up and down navigation buttons in a menu.

Press the Return button (↩) to view the previous channel.

To select a subchannel, select a channel, press the Subchannel button (●), and then press the numbered channel buttons.

Press the Menu button to view the main menu or to view a previous menu. See pages 24 and 25 for information on the menu.

Press the Exit button to exit any menu.

Press the PRLIST button to view a list of channels. If you have labeled any channels, the menu will also show the channel label. See page 25 for information on labeling channels. Note: You can also view this list by pressing the OK/Auto button on the console.

Press the EPG button to view the electronic program guide. Note: The electronic program guide is only available when viewing ATSC digital television.

Press the Info button to view information about the current program and the broadcast or cable signal.

Press the CC button repeatedly to turn on or turn off closed captioning. See step 5 on page 24 to adjust closed captioning settings.

Press the TV/AV button repeatedly to select the input source. To view television channels through an antenna or a CATV cable, select the TV source. To use the audio/video wire harness, select the AV source.

Press the MTS button repeatedly to select mono, stereo, or SAP (secondary audio programming) as the audio setting.

Press the Format button repeatedly to select auto, 4:3, or wide image as the display format. Note: The auto display format is only available when viewing ATSC digital television.

Press the Pict button repeatedly to select standard, dynamic, soft, or personal as the image mode.

Press the Audio button repeatedly to select standard, music, movie, or personal as the audio mode.

## HOW TO REPLACE THE BATTERIES IN THE REMOTE CONTROL

To replace the batteries, first locate the battery cover on the back of the remote control. Push down lightly on the battery cover with your thumb and slide off the battery cover.

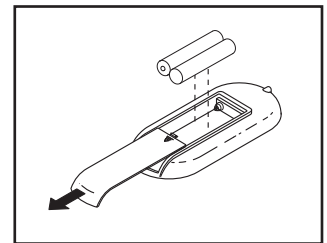

Next, remove the old batteries from the remote control, and insert two new “AAA” batteries. **Make sure to insert the batteries as shown in the drawing.** Then, slide the battery cover onto the remote control.

## HOW TO ADJUST THE TELEVISION SETTINGS

You must use your remote control to adjust television settings. Press the Menu button to enter the main menu or to return to a previous menu. Press the Exit button to exit a menu. Press the Channel (CH) increase and decrease buttons to navigate up and down in a menu and the Volume (VOL) increase and decrease buttons on your remote control to navigate right and left.

### 1. Press the Menu button to enter the main menu.

To select one of the icons across the top of the screen, press the Volume increase and decrease buttons on your remote control until the desired icon appears larger than the others.

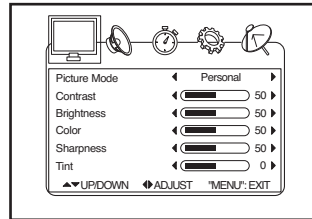

Select the monitor to adjust the image settings. Select the speaker to adjust the audio settings. Select the clock to adjust the time settings. Select the gear to adjust the television settings. Select the antenna to locate and save channels. To return to the main menu, press the Menu button repeatedly.

### 2. Adjust the image settings.

Select the personal, standard, dynamic, or soft picture mode. The contrast, brightness, color, sharpness, and tint will automatically adjust. You can also manually adjust the contrast, brightness, color, sharpness, or tint.

### 3. Adjust the audio settings.

Select the personal, standard, movie, or music sound mode. The bass, treble, and balance will automatically adjust. You can also manually adjust the bass, treble, balance, or audio language. Select an audio language to hear programs in the selected language. Note: The audio language setting will function only if another audio signal is available.

### 4. Adjust the time settings.

Adjust the OSD (on-screen display) duration, sleep timer, time zone, or daylight savings time settings. The clock will display the current date and time and is reset every time the power is turned on. The OSD duration is the length of time indicators (like channel number or the electronic program guide) will remain on the screen after they appear. If you set the sleep timer, the television will turn off after the indicated number of minutes. A countdown will warn you when the television is about to turn off. Note: The time zone setting, daylight savings time setting, and clock are only available when viewing digital television.

### 5. Adjust the television settings.

Adjust the language used in the menus, the transparency of the menu, the color mode, or the closed caption settings. You can also restore the original television settings.

To enter the closed caption submenu, highlight CLOSED CAPTION and press the Volume increase button on your remote control. In the closed caption submenu, adjust the closed caption mode, the basic selection, and the advanced selection.

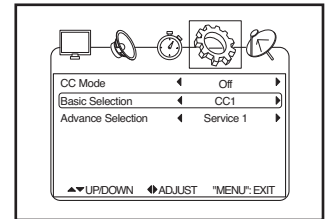

When you highlight RESTORE SETTING and press the Volume increase button, a confirmation request will appear in the display. Use the Volume increase or decrease button to select YES or NO and press the Channel increase or decrease button to confirm your selection.

Select YES to restore the original television settings or NO to keep the current settings.

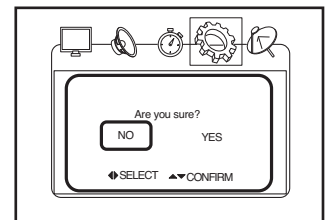



## 6. Scan and save channels.

Select CATV or AIR. Select CATV to receive cable channels through the 75 ohm terminal on the treadmill. Select AIR to receive channels through an antenna.

To scan for available channels, highlight AUTO SCAN or AUTO SCAN ADD CH. To scan all channels, select the Auto scan option. To scan all channels and add an extra channel, select the Auto Scan Add Ch option. The scan channel submenu will appear.

If you are receiving channels through a CATV cable, highlight CABLE SYSTEM and select the auto, STD, IRC, or HRC setting. Try all four cable settings, if necessary, to find the optimal setting.

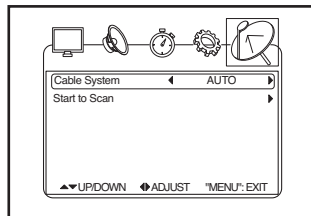

Highlight START TO SCAN and press the Volume increase button to start the auto scan. The television will begin scanning all of the channels available in your area. When no signal is detected on a channel, the channel will be skipped. When a signal is detected, the channel will be saved into memory and the next channel will be selected. This process will continue until the highest channel is reached. The television will renumber the channels in the order in which it locates them. **Do not remove the key while the television is scanning channels.** Note: If a television channel disappears, scan for channels again.

After all valid channels available in your area have been saved into the television's memory, you can manually skip unwanted channels.

To skip a channel, highlight CHANNEL SKIP and press the Volume increase button on your remote control. In the channel skip submenu, press the Channel increase and decrease buttons to highlight the desired channel and the Volume increase and decrease buttons to turn on or turn off the skip option. Continue this process until you have skipped all unwanted channels.

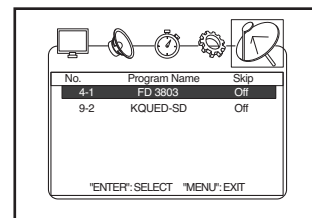

To change the display name of a channel, highlight CHANNEL NO. and select a channel. Then, highlight CHANNEL LABEL and press the Volume increase button to enter the channel label submenu. Press the Volume increase and decrease buttons to select a number or letter box. Then press the Channel increase and decrease buttons to select the desired number or letter.

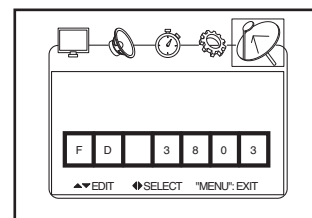

## 7. Exit the Menu.

When you have finished adjusting the settings, press the Exit button.

## THE INFORMATION MODE

The console features an information mode that keeps track of the total distance that the walking belt has moved and the total number of hours that the treadmill has been used. The information mode also allows you to select miles or kilometers to measure distance, and to turn on and turn off the display demo mode.

To select the information mode, hold down the Start/Stop button while inserting the key into the console and then release the Start/Stop button. When the information mode is selected, the following information will be shown:

The Time/Incline display will show the total number of hours the treadmill has been used.



An “E” for English miles or an “M” for metric kilometers will appear in the Calorie/Pulse display. Press the Speed increase button to change the unit of measurement if desired.

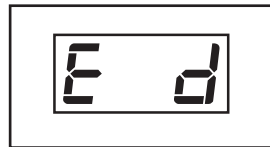

The console features a display demo mode, designed to be used if the treadmill is displayed in a store. While the demo mode is turned on, the console will function normally when you plug in the power cord, switch the reset/off circuit breaker to the reset position, and insert the key into the console. However, when you remove the key, the displays will remain lit, although the buttons will not function. If the demo mode is turned on, a “d” will appear in the Calorie/Pulse display while the information mode is selected. To turn on or turn off the demo mode, press the Speed decrease button.

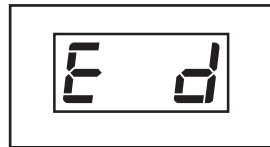

The Distance/Speed display will show the total number of miles or kilometers that the walking belt has moved.

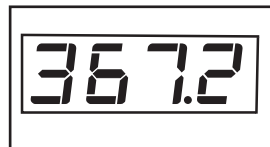

To exit the information mode, remove the key from the console.

## HOW TO USE THE STEREO SOUND SYSTEM

To play music or audio books through the console's stereo speakers, you must connect your MP3 player, CD player, or other personal audio player to the console through the audio jack.

To use the audio jack, locate the audio wire and plug it into the audio jack labeled IN. Then plug the audio wire into a jack on your MP3 player, CD player, or other personal audio player. **Make sure that the audio wire is fully plugged in.** While the audio wire is plugged in, the television audio will not function.

Next, press the Play button on your MP3 player, CD player, or other personal audio player. Adjust the volume on your personal audio player or press the Volume increase and decrease buttons on the console. To use headphones, plug the headphones into the headphone jack near the audio jack.

If you are using a personal CD player and the CD skips, set the CD player on the floor or another flat surface and not on the console.

## THE OPTIONAL CHEST PULSE SENSOR

An optional chest pulse sensor offers hands-free operation as it tracks your heart rate during your workouts. **To purchase the optional chest pulse sensor, call the telephone number on the front cover of this manual.**

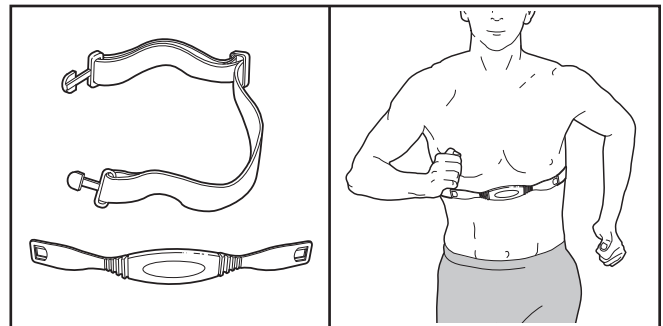

# HOW TO FOLD AND MOVE THE TREADMILL

## HOW TO FOLD THE TREADMILL FOR STORAGE

Before folding the treadmill, adjust the incline to the lowest position. If you do not do this, you may damage the treadmill when you fold it. Remove the key and unplug the power cord. **CAUTION:** You must be able to safely lift 45 lbs. (20 kg) to raise, lower, or move the treadmill.

1. Hold the metal frame firmly in the location shown by the arrow at the right. **CAUTION:** To decrease the possibility of injury, do not lift the frame by the plastic foot rails. To raise the frame, bend your legs, keep your back straight, and lift with your legs. Raise the frame about halfway to the vertical position.

2. Raise the frame until the latch knob locks into the storage position. **Make sure that the latch knob is locked in the storage position.**

To protect the floor or carpet from damage, place a mat under the treadmill. Keep the treadmill out of direct sunlight. Do not leave the treadmill in the storage position in temperatures above 85° F (30° C).

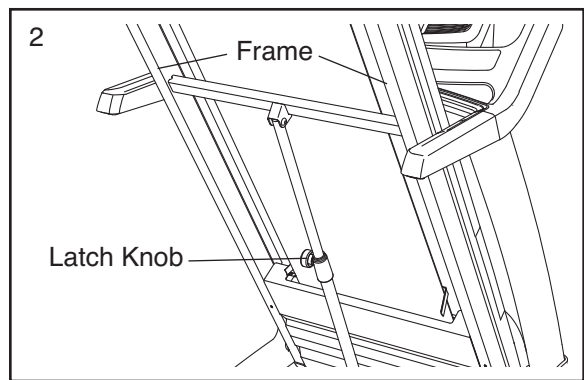
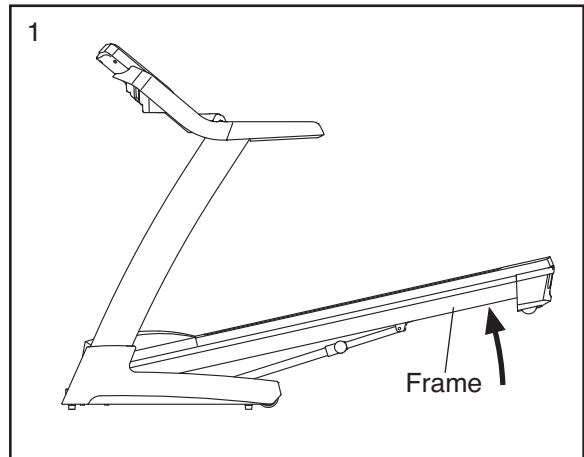

## HOW TO MOVE THE TREADMILL

Before moving the treadmill, convert the treadmill to the storage position as described above. **Make sure that the latch knob is locked in the storage position.**

1. Hold the handrails and place one foot against one of the wheels.
2. Tip the treadmill back until it rolls freely on the wheels. Carefully move the treadmill to the desired location. **Never move the treadmill without tipping it back. To reduce the risk of injury, use extreme caution while moving the treadmill. Do not attempt to move the treadmill over an uneven surface.**
3. Place one foot against one of the wheels, and carefully lower the treadmill until it is resting in the storage position.

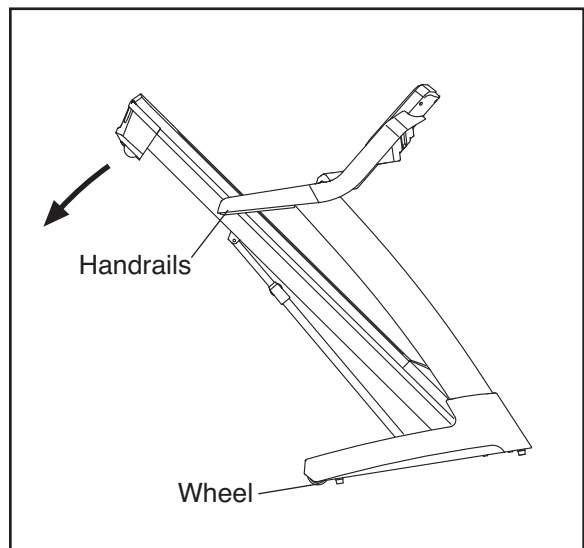

## HOW TO LOWER THE TREADMILL FOR USE

1. **See drawing 2.** Hold the upper end of the treadmill with your right hand. Pull the latch knob to the left and hold it. Pivot the frame downward and release the latch knob. Note: It may be necessary to push the frame forward as you pull the latch knob to the left.
2. **See drawing 1.** Hold the metal frame firmly with both hands, and lower it to the floor. **CAUTION:** To decrease the possibility of injury, do not lower the frame by gripping only the plastic foot rails. Do not drop the frame to the floor. Make sure to bend your legs and keep your back straight.

# TROUBLESHOOTING

Most treadmill problems can be solved by following the steps below. Find the symptom that applies, and follow the steps listed. If further assistance is needed, please see the front cover of this manual.

**PROBLEM: The power does not turn on**

**SOLUTION:** a. Make sure that the power cord is plugged into a surge suppressor, and that the surge suppressor is plugged into a properly grounded outlet (see page 14). Use only a single-outlet surge suppressor that meets all of the specifications described on page 14. **IMPORTANT: The treadmill is not compatible with GFCI-equipped outlets.**

b. After the power cord has been plugged in, make sure that the key is inserted into the console.

c. Check the reset/off circuit breaker located on the treadmill frame near the power cord. If the switch protrudes as shown, the circuit breaker has tripped. To reset the circuit breaker, wait for five minutes and then press the switch to the reset position.

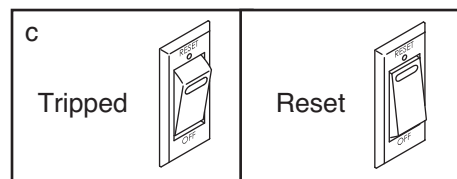

**PROBLEM: The power turns off during use**

**SOLUTION:** a. Check the reset/off circuit breaker (see the drawing above). If the circuit breaker has tripped, wait for five minutes and then press the switch to the reset position.

b. Make sure that the power cord is plugged in. If the power cord is plugged in, unplug it, wait for five minutes, and then plug it back in.

c. Remove the key from the console. Reinsert the key into the console.

d. If the treadmill still will not run, please see the front cover of this manual.

**PROBLEM: The console displays remain lit when you remove the key from the console**

**SOLUTION:** a. The console features a display demo mode, designed to be used if the treadmill is displayed in a store. If the displays remain lit when you remove the key, the demo mode is turned on. To turn off the demo mode, hold down the Stop button for a few seconds. If the displays are still lit, see THE INFORMATION MODE on page 26 to turn off the demo mode.

**PROBLEM: The displays of the console do not function properly**

**SOLUTION:** a. Remove the key from the console and **UNPLUG THE POWER CORD**. Place the treadmill in the storage position (see HOW TO FOLD AND MOVE THE TREADMILL on page 27).

Next, remove the two indicated #8 x 3/4" Screws (7).

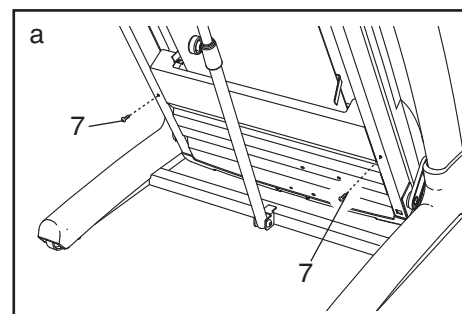

Lower the treadmill (see HOW TO LOWER THE TREADMILL FOR USE on page 27). Remove the four indicated #8 x 3/4" Screws (7), and remove the Motor Hood (66).

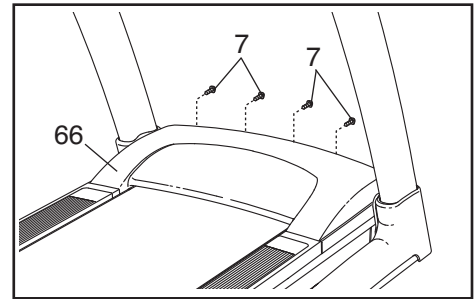

Next, locate the Reed Switch (48) and the Magnet (124) on the left side of the Pulley (54). Turn the Pulley until the Magnet is aligned with the Reed Switch. **Make sure that the gap between the Magnet and the Reed Switch is about 1/8 in. (3 mm).** If necessary, loosen the indicated #8 x 3/4" Washer Head Tek Screw (26), move the Reed Switch slightly, and then retighten the Tek Screw. Reattach the Hood (not shown) with the six #8 x 3/4" Screws (not shown). Run the treadmill for a few minutes to check for a correct speed reading.

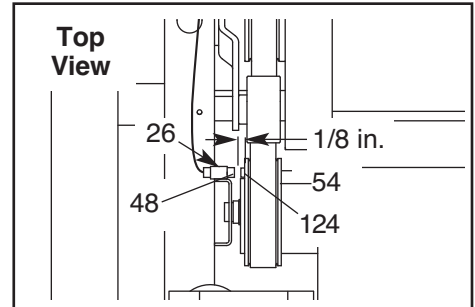

**PROBLEM: The incline of the treadmill does not change correctly**

**SOLUTION:** a. Hold down the Stop button and the Speed increase button, insert the key into the console, and then release the Stop button and the Speed increase button. Press the Stop button again. Press the Incline increase or decrease button. The treadmill will automatically rise to the maximum incline level and then return to the minimum level. This will recalibrate the incline system. If the incline does not calibrate, press the Stop button, and then press the Incline increase or decrease button again. When the incline is calibrated, remove the key from the console.

**PROBLEM: The walking belt slows when walked on**

**SOLUTION:** a. Use only a single-outlet surge suppressor that meets all of the specifications described on page 14.

b. If the walking belt is overtightened, treadmill performance may decrease and the walking belt may become damaged. Remove the key and **UNPLUG THE POWER CORD.** Using the hex key, turn both idler roller bolts counterclockwise, 1/4 of a turn. When the walking belt is properly tightened, you should be able to lift each edge of the walking belt 3 to 4 in. (8 to 10 cm) off the walking platform. Be careful to keep the walking belt centered. Then, plug in the power cord, insert the key, and run the treadmill for a few minutes. Repeat until the walking belt is properly tightened.

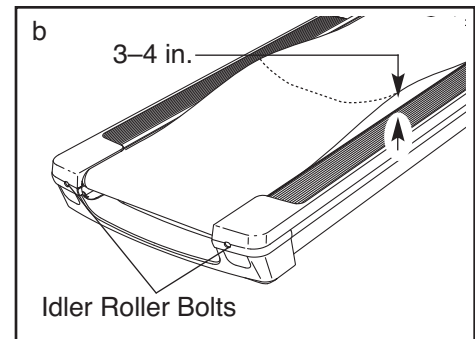

c. If the walking belt still slows when walked on, please see the front cover of this manual.

**PROBLEM: The walking belt is off-center or slips when walked on**

**SOLUTION:** a. If the walking belt is off-center, remove the key and **UNPLUG THE POWER CORD**. If the walking belt has shifted to the left, use the hex key to turn the left idler roller bolt clockwise 1/2 of a turn; if the walking belt has shifted to the right, turn the left idler roller bolt counterclockwise 1/2 of a turn. Be careful not to overtighten the walking belt. Plug in the power cord, insert the key, and run the treadmill for a few minutes. Repeat until the walking belt is centered.

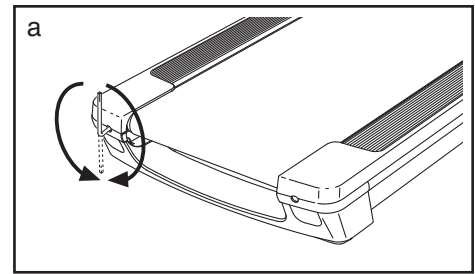

b. If the walking belt slips when walked on, first remove the key and **UNPLUG THE POWER CORD**. Using the hex key, turn both idler roller bolts clockwise, 1/4 of a turn. When the walking belt is correctly tightened, you should be able to lift each edge of the walking belt 3 to 4 in. (8 to 10 cm) off the walking platform. Be careful to keep the walking belt centered. Then, plug in the power cord, insert the key, and carefully walk on the treadmill for a few minutes. Repeat until the walking belt is properly tightened.

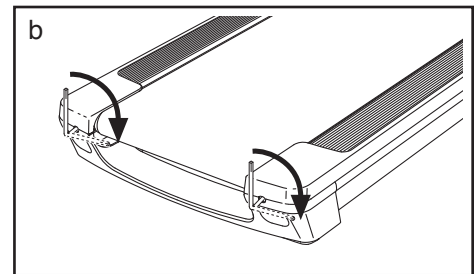

**PROBLEM: Television reception is poor**

**SOLUTION:** a. Make sure that the television settings are set correctly. See HOW TO ADJUST THE TELEVISION SETTINGS on page 24.

b. For the digital television to operate properly, good reception is necessary. If you are using an antenna, make sure that it is properly connected and adjusted for optimal reception. (See HOW TO CONNECT AN ANTENNA on page 13.)

c. Check for the problems listed below and follow the applicable instructions.

- Ignition (black spots or horizontal streaks that appear on a picture that flutters or drifts)— Usually this is caused by interference from automobile ignition systems, neon lamps, electric drifts, or other electric appliances. Try changing the position of the treadmill or other electric appliances to correct the problem.
- Ghosts—Ghosts are caused by the television signal following two paths—one is the direct path and the other is reflected from tall buildings, hills, or other objects. Change the direction or position of the antenna to improve reception.
- Blue Screen—If the treadmill is located in the fringe area of a television station where the signal is weak, the picture may be of poor quality or a blue screen may appear. If the signal is weak, it may be necessary to install an external antenna to improve the picture.
- Fading—If blocks of the picture are missing, the picture moves around the screen, or the picture disappears, the signal may be weak. Change the direction or position of the antenna to improve reception. Make sure the television settings are set correctly (see HOW TO ADJUST TELEVISION SETTINGS on page 24). Do not use a splitter.

Note: If one of these problems appears when the cable from a CATV company is connected, the problem may be caused by the cable company broadcast.

**PROBLEM: The remote control does not function correctly**

- SOLUTION:** a. Make sure you are standing on the treadmill, holding the remote control near the television and pointing the remote control directly at the console.
- b. If your remote control is still not functioning correctly, the batteries should be replaced; most remote control problems are the result of low batteries. See page 23 to replace the batteries.

**PROBLEM: The television is not receiving a signal**

- SOLUTION:** a. Make sure the correct TV or AV source is selected. See step 3 on page 22 to select a television source.
- b. Make sure that the antenna cable, CATV cable, or 96" A/V Wire is connected securely to the treadmill. See page 13 to connect a cable to treadmill.
- c. Scan for broadcast or cable signals. See page 25 to scan for signals.
- d. Due to an FCC requirement, analog signals will no longer be broadcast over the air after June 12, 2009. If you wish to view television signals through an antenna after this date, you must have an antenna capable of receiving digital signals. Cable television will not be affected.

**PROBLEM: The volume is too loud or the television audio makes a crackling sound**

- SOLUTION:** a. If the television audio makes a crackling sound when the volume is turned up, the volume is too loud. Press the Volume increase or decrease button on the remote control until the volume level is 80 percent. Once the volume reaches 80 percent, adjust the volume by pressing the Volume buttons on the console only.

**PROBLEM: The volume cannot be turned up**

- SOLUTION:** a. If the volume cannot be turned up, the volume may have been adjusted with the remote control. Press the Volume increase or decrease button on the remote control until the volume level is 80 percent. Once the volume reaches 80 percent, adjust the volume by pressing the Volume buttons on the console only.
- b. If there is no sound coming from the television, make sure the television audio is not muted.

**PROBLEM: The television needs to be cleaned**

- SOLUTION:** a. **UNPLUG THE POWER CORD.** To clean the television, wipe the television and screen using a soft cloth with a small amount of soft detergent. **Do not use a polishing cloth, solvent, or any type of propellant or chemical detergent such as alcohol or benzene.**

# EXERCISE GUIDELINES

**⚠ WARNING:** Before beginning any exercise program, consult your physician. This is especially important for persons over age 35 or persons with pre-existing health problems.

The pulse sensor is not a medical device. Various factors may affect the accuracy of heart rate readings. The pulse sensor is intended only as an exercise aid in determining heart rate trends in general.

These guidelines will help you to plan your exercise program. For detailed exercise information, obtain a reputable book or consult your physician. Remember, proper nutrition and adequate rest are essential for successful results.

## EXERCISE INTENSITY

Whether your goal is to burn fat or to strengthen your cardiovascular system, exercising at the proper intensity is the key to achieving results. You can use your heart rate as a guide to find the proper intensity level. The chart below shows recommended heart rates for fat burning and aerobic exercise.

165	155	145	140	130	125	115	♥
145	138	130	125	118	110	103	♥
125	120	115	110	105	95	90	♥
<hr/>							
20	30	40	50	60	70	80	

To find the proper intensity level, find your age at the bottom of the chart (ages are rounded off to the nearest ten years). The three numbers listed above your age define your “training zone.” The lowest number is the heart rate for fat burning, the middle number is the heart rate for maximum fat burning, and the highest number is the heart rate for aerobic exercise.

**Burning Fat**—To burn fat effectively, you must exercise at a low intensity level for a sustained period of time. During the first few minutes of exercise, your body uses *carbohydrate calories* for energy. Only after the first few minutes of exercise does your body begin to use stored *fat calories* for energy. If your goal is to burn fat, adjust the intensity of your exercise until your heart rate is near the lowest number in your training zone. For maximum fat burning, exercise with your heart rate near the middle number in your training zone.

**Aerobic Exercise**—If your goal is to strengthen your cardiovascular system, you must perform aerobic exercise, which is activity that requires large amounts of oxygen for prolonged periods of time. For aerobic exercise, adjust the intensity of your exercise until your heart rate is near the highest number in your training zone.

## WORKOUT GUIDELINES

**Warming Up**—Start with 5 to 10 minutes of stretching and light exercise. A warm-up increases your body temperature, heart rate, and circulation in preparation for exercise.

**Training Zone Exercise**—Exercise for 20 to 30 minutes with your heart rate in your training zone. (During the first few weeks of your exercise program, do not keep your heart rate in your training zone for longer than 20 minutes.) Breathe regularly and deeply as you exercise—never hold your breath.

**Cooling Down**—Finish with 5 to 10 minutes of stretching. Stretching increases the flexibility of your muscles and helps to prevent post-exercise problems.

## EXERCISE FREQUENCY

To maintain or improve your condition, complete three workouts each week, with at least one day of rest between workouts. After a few months of regular exercise, you may complete up to five workouts each week, if desired. Remember, the key to success is to make exercise a regular and enjoyable part of your everyday life.



# PART LIST—Model No. EPTL99609.0

R0809A

To locate the parts listed below, see the EXPLODED DRAWING near the end of this manual.

Key No.	Qty.	Description	Key No.	Qty.	Description
1	4	3/8" x 1 1/4" Patch Bolt	51	2	Lift Arm
2	4	3/8" x 3 3/4" Patch Bolt	52	1	Reed Switch Clamp
3	2	3/8" x 3/4" Bolt	53	2	Incline Rod Spacer
4	1	Incline Button	54	1	Drive Roller/Pulley
5	1	3/8" x 1 3/4" Bolt	55	1	Electronics Bracket
6	1	3/8" x 2" Bolt	56	1	Controller
7	42	#8 x 3/4" Screw	57	1	Front Cap
8	10	3/8" Star Washer	58	1	Reset/Off Circuit Breaker
9	8	3/8" Nut	59	1	Power Cord Grommet
10	2	5/16" Drive Motor Bolt	60	2	Isolator
11	1	3/8" x 1 3/4" Hex Bolt	61	1	Frame
12	1	3/8" x 2" Hex Bolt	62	1	40" TV Cable
13	2	Handrail Cap	63	1	Power Cord
14	2	Console Ground Wire	64	1	Idler Roller
15	4	#8 Belt Guide Screw	65	1	Hex Key
16	2	1/4" x 2 1/2" Bolt	66	1	Motor Hood
17	59	#8 x 1/2" Screw	67	1	Incline Rod
18	1	Key Plate	68	1	Incline Motor
19	2	1/4" x 1 1/4" Bolt	69	1	Incline Motor Wire
20	2	5/16" x 1 1/4" Bolt	70	1	Stop Bracket Spacer
21	12	#12 x 1" Screw	71	1	Stop Bracket
22	2	3/8" x 3/4" Bolt	72	1	Drive Motor Belt
23	2	3/8" x 1 3/4" Patch Bolt	73	1	Drive Motor
24	2	3/8" x 2 3/8" Bolt	74	1	Left Rail Cover
25	9	#8 x 1/2" Bright Screw	75	1	Left Foot Rail
26	13	#8 x 3/4" Washer Head Tek Screw	76	1	Right Foot Rail
27	4	#8 x 1" Screw	77	1	Latch Knob
28	4	1/4" Star Washer	78	1	Storage Latch
29	1	3/8" Star Washer	79	1	Latch Cap
30	1	Speed Button	80	1	65" A/V Wire
31	2	1/4" Lock Washer	81	1	65" TV Cable
32	4	Base Foot Spacer	82	4	Releasable Tie
33	4	1/4" Nut	83	1	Right Rail Cover
34	1	#8 Nut	84	10	8" Cable Tie
35	2	3/8" Cable Nut	85	1	Left Upright
36	4	Hood Clip	86	1	Upright Wire
37	2	5/16" Flange Nut	87	2	Upright Wire Grommet
38	1	M12 Nut	88	1	Right Upright
39	2	1/4" x 1/2" Bolt	89	1	Speaker Base
40	2	Rear Wheel Axle	90	1	Left Accessory Tray
41	4	Rear Wheel	91	1	Small Left Pulse Sensor
42	1	Right Platform Cushion	92	1	Large Left Pulse Sensor
43	1	Warning Decal	93	1	Incline Control
44	1	Walking Platform	94	1	Pulse Bar
45	1	Left Platform Cushion	95	1	Pulse Receiver Cover
46	2	Belt Guide	96	2	Console Ground Wire
47	1	Walking Belt	97	1	Console Insert
48	1	Reed Switch	98	1	Console Back
49	2	Motor Hood Mount	99	1	Speed Control
50	2	Lift Arm Spacer	100	1	Right Accessory Tray

Key No.	Qty.	Description	Key No.	Qty.	Description
101	1	96" A/V Wire	122	1	18" Audio Wire
102	1	Left Handrail	123	1	Remote Control
103	1	Right Handrail	124	1	Magnet
104	1	Right Bottom Handrail Cover	125	1	Filter Wire
105	1	Console Crossbar	126	1	Console Base
106	1	Left Bottom Handrail Cover	127	1	TV
107	1	Left Handrail Cover	128	1	Left Console Fan
108	1	Right Handrail Cover	129	1	Rear Foot
109	1	Console Cover	130	2	Speaker
110	1	Key/Clip	131	1	Rear Foot Insert
111	1	Static Decal	132	1	Left Foot Insert
112	4	Caution Decal	133	1	Right Foot Insert
113	4	Base Foot	134	8	#6 x 1/4" Screw
114	1	A/V Cover	135	10	#3 x 1/4" Screw
115	1	Base	136	1	Console Cover
116	2	Wheel	137	1	Right Console Fan
117	1	Right Base Cover	138	1	Right Small Pulse Sensor
118	1	Left Base Cover	139	1	Right Large Pulse Sensor
119	4	Wire Tie	*	-	4" White Wire, M/F
120	8	Console Clamp	*	-	User's Manual
121	1	5/32" Hex Key			

Note: Specifications are subject to change without notice. For information about ordering replacement parts, see the back cover of this manual. \*These parts are not illustrated.

# EXPLODED DRAWING A—Model No. EPTL99609.0

R0809A

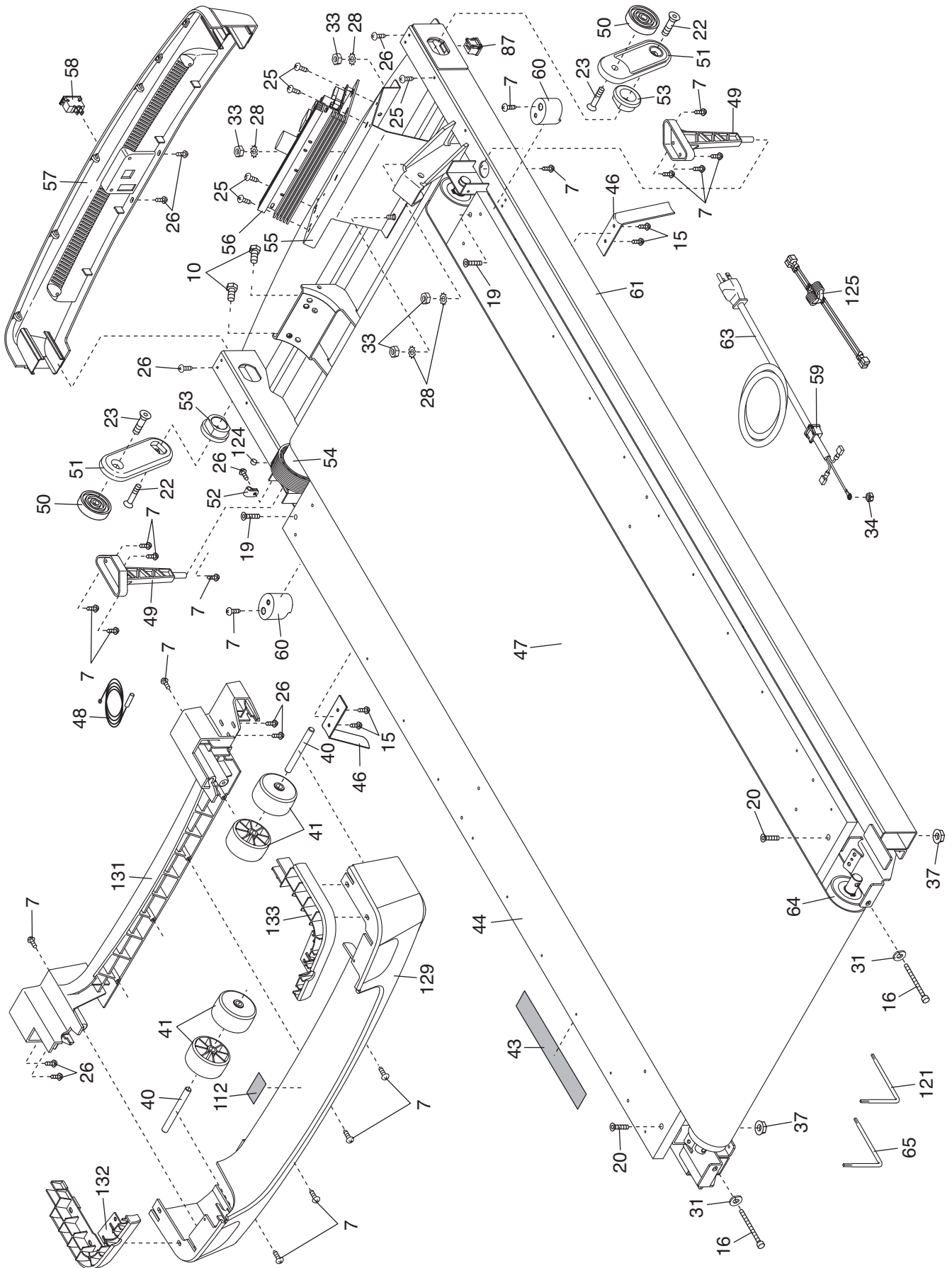

# EXPLODED DRAWING B—Model No. EPTL99609.0

R0809A

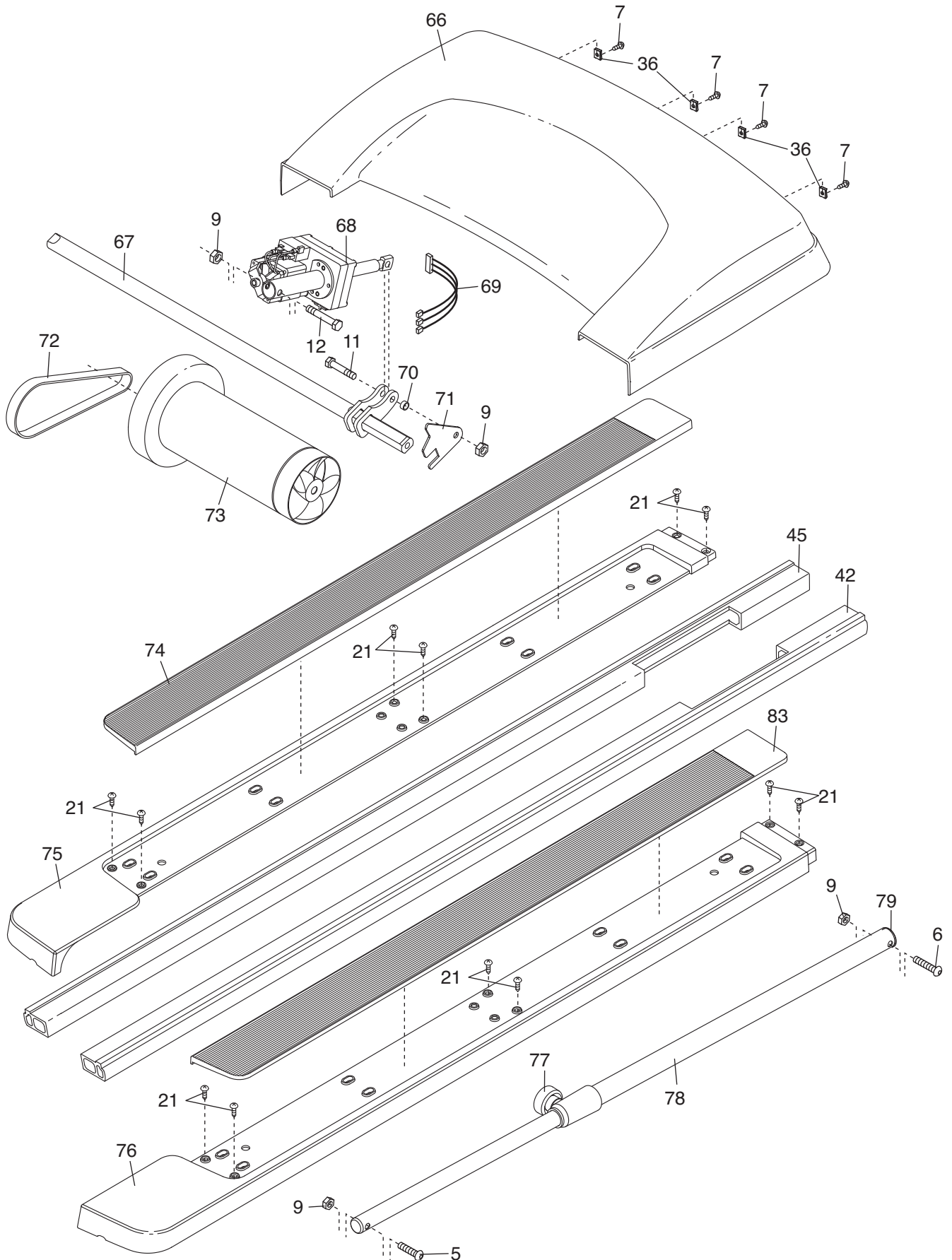

# EXPLODED DRAWING C—Model No. EPTL99609.0

R0809A

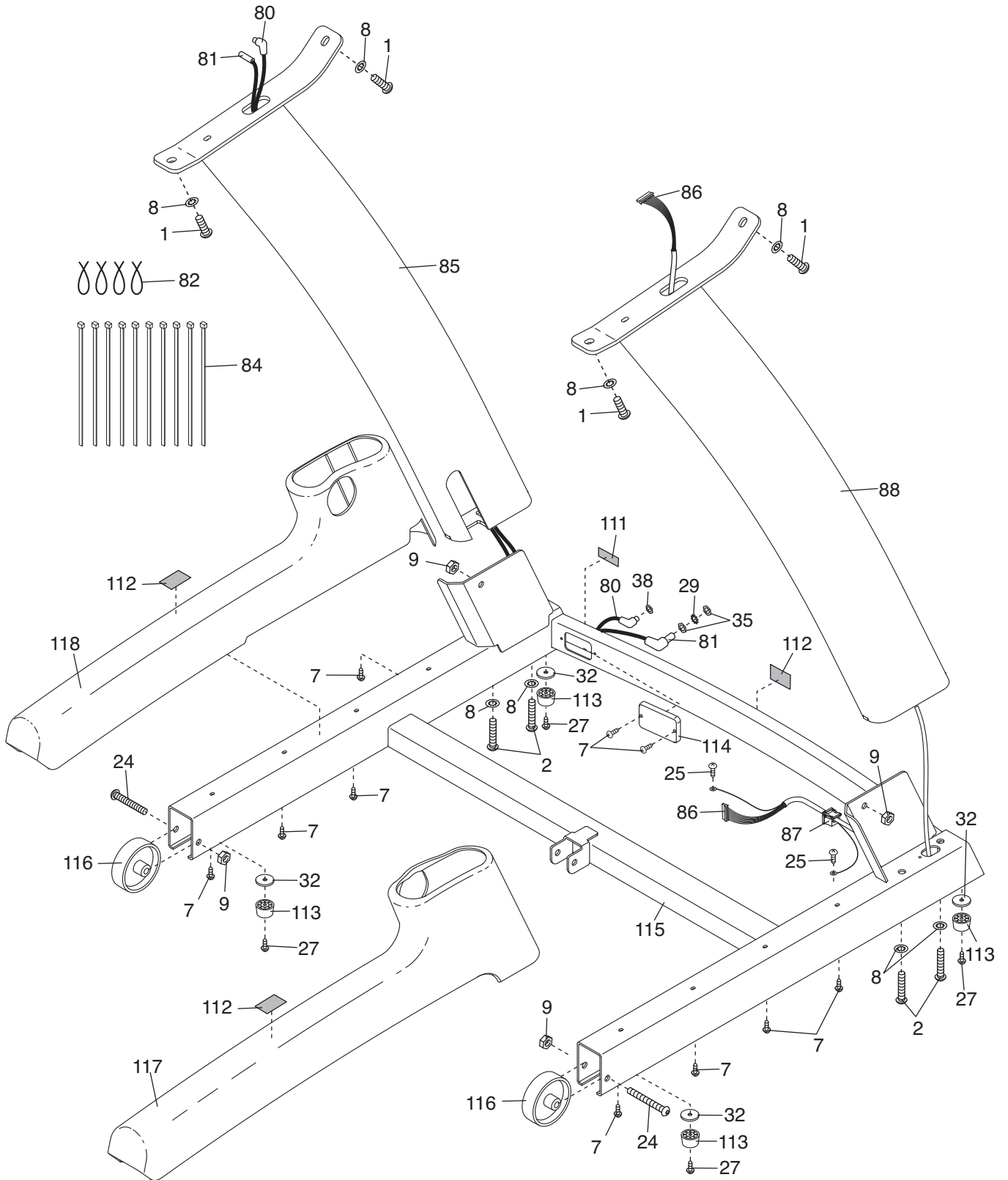

# EXPLODED DRAWING D—Model No. EPTL99609.0

R0809A

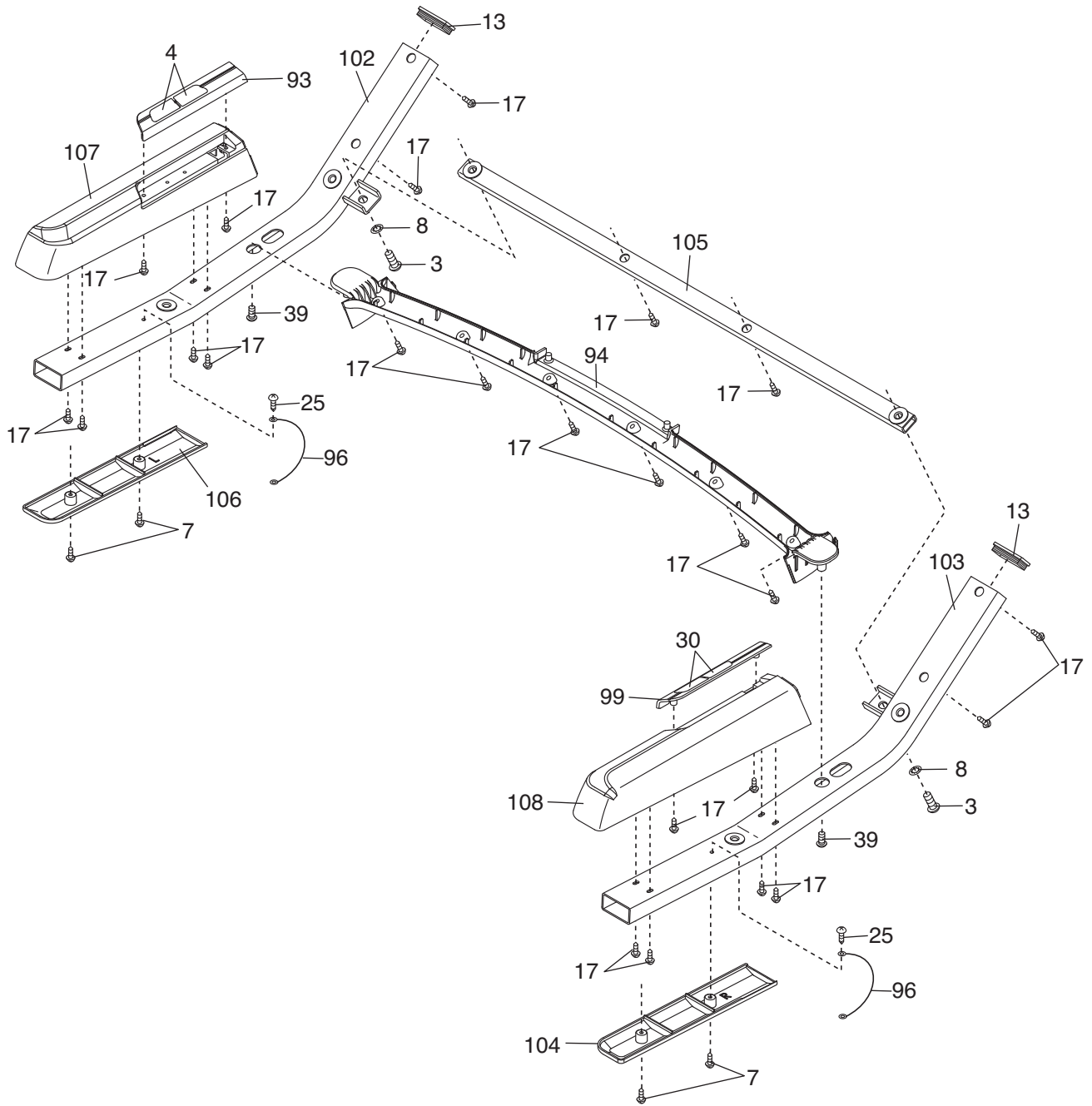

# EXPLODED DRAWING E—Model No. EPTL99609.0

R0809A

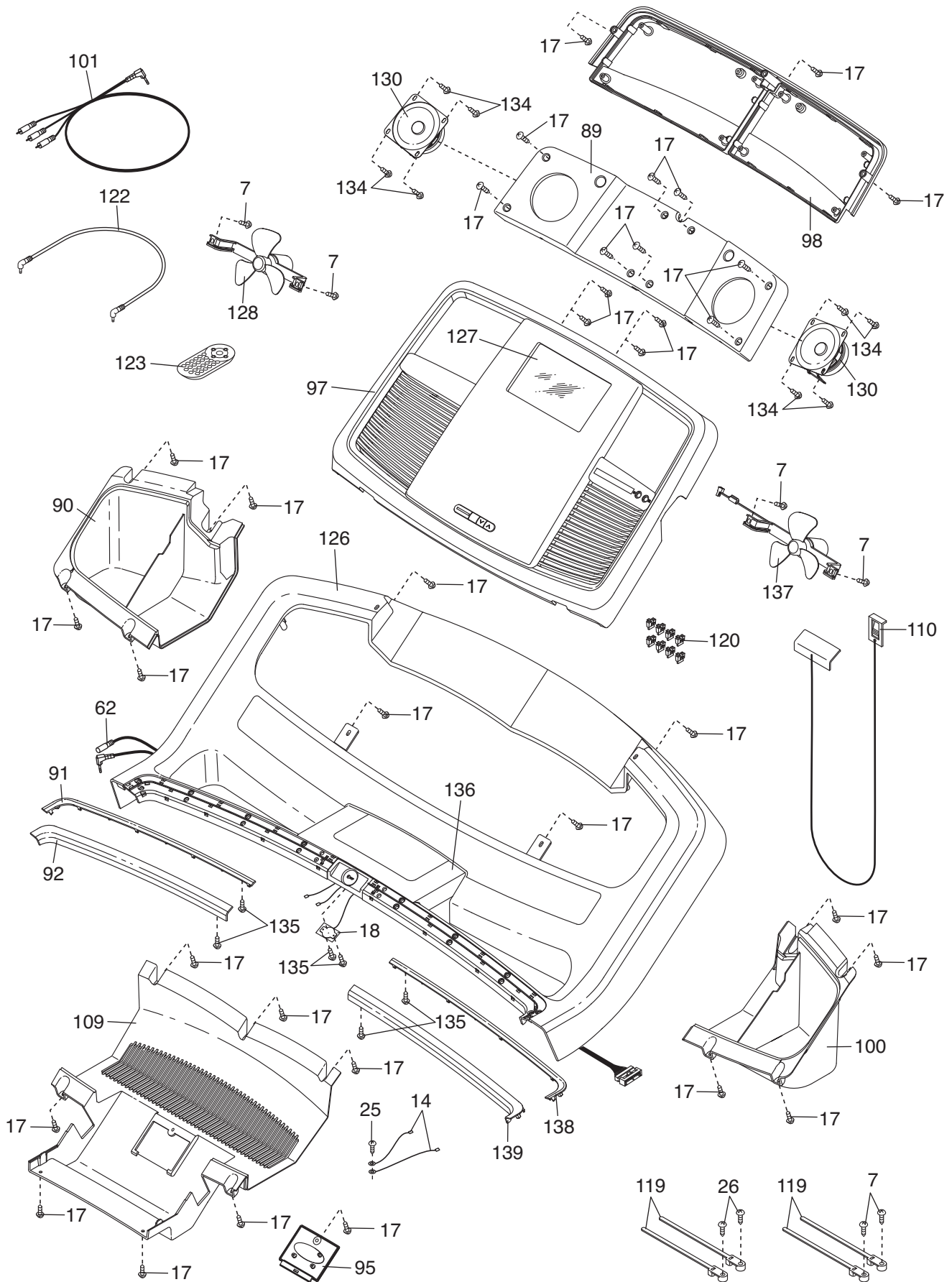

---

# ORDERING REPLACEMENT PARTS

To order replacement parts, please see the front cover of this manual. To help us assist you, be prepared to provide the following information when contacting us:

- the model number and serial number of the product (see the front cover of this manual)
- the name of the product (see the front cover of this manual)
- the key number and description of the replacement part(s) (see the PART LIST and the EXPLODED DRAWING near the end of this manual)

## LIMITED WARRANTY

**IMPORTANT: You must register this product within 30 days of the purchase date to avoid added fees for service needed under warranty. Go to [www.iconservice.com/registration](http://www.iconservice.com/registration).**

ICON Health & Fitness, Inc. (ICON) warrants this product to be free from defects in workmanship and material, under normal use and service conditions. The frame and drive motor are warranted for a lifetime. Parts and labor are warranted for one (1) year from the date of purchase.

This warranty extends only to the original purchaser. ICON's obligation under this warranty is limited to repairing or replacing, at ICON's option, the product through one of its authorized service centers. All repairs for which warranty claims are made must be preauthorized by ICON. If the product is shipped to a service center, freight charges to and from the service center will be the customer's responsibility. For replacement parts shipped while the product is under warranty, the customer will be responsible for a minimal handling charge. For in-home service, the customer will be responsible for a minimal trip charge. This warranty does not extend to any damage to a product caused by or attributable to freight damage, abuse, misuse, improper or abnormal usage, or repairs not provided by an ICON authorized service center; to products used for commercial or rental purposes or as store display models; or to products transported or purchased outside the US. No other warranty beyond that specifically set forth above is authorized by ICON.

ICON is not responsible or liable for indirect, special, or consequential damages arising out of or in connection with the use or performance of the product; damages with respect to any economic loss, loss of property, loss of revenues or profits, loss of enjoyment or use, or costs of removal or installation; or other consequential damages of whatsoever nature. Some states do not allow the exclusion or limitation of incidental or consequential damages. Accordingly, the above limitation may not apply to you.

The warranty extended hereunder is in lieu of any and all other warranties, and any implied warranties of merchantability or fitness for a particular purpose are limited in their scope and duration to the terms set forth herein. Some states do not allow limitations on how long an implied warranty lasts. Accordingly, the above limitation may not apply to you.

This warranty gives you specific legal rights. You may also have other rights that vary from state to state.

**ICON Health & Fitness, Inc., 1500 S. 1000 W., Logan, UT 84321-9813**